

# *Jellyfish*<sup>®</sup> Filter

## Technical Manual



**imbrium**<sup>®</sup>

Engineered Stormwater Treatment  
[www.imbriumsystems.com](http://www.imbriumsystems.com)

# Jellyfish<sup>®</sup> Filter

## Highlights

The Jellyfish<sup>®</sup> Filter is an engineered Stormwater quality treatment technology featuring pre-treatment and membrane filtration in a compact stand-alone treatment system that removes a high level and wide variety of Stormwater pollutants. Exceptional pollutant removal is achieved at high treatment flow rates with minimal head loss and low maintenance costs. Each lightweight Jellyfish Filter cartridge contains an extraordinarily large amount of membrane surface area, resulting in superior flow capacity and pollutant removal capacity.

**Jellyfish efficiently captures a high level of stormwater pollutants, including:**

### **Pollutant Removal\***

- ✓ Total Suspended Solids (TSS), median removal efficiency of 89%, including particles less than 2 microns
- ✓ Suspended Solids Concentration (SSC) 99%
- ✓ Total Nitrogen (TN), median removal efficiency of 51%
- ✓ Total Phosphorus (TP), median removal efficiency of 59%
- ✓ Total Copper (Cu), median removal efficiency of 90%
- ✓ Total Zinc (Zn), median removal efficiency of 70%
- ✓ Free Oil
- ✓ Floatable trash and debris 100%

\* Based on 3<sup>rd</sup> party field testing

**Jellyfish Filter field test performance results have been verified by the New Jersey Corporation for Advanced Technology (NJCAT), through the TARP program.**



# Jellyfish® Filter Technical Manual

---

**Imbrium Systems**  
Engineered Stormwater Treatment  
[www.imbriumsystems.com](http://www.imbriumsystems.com)

**USA**

**Phone:** 301.279.8827  
**Toll Free:** 888.279.8826

**Canada/International**

**Phone:** 416.960.9900  
**Toll Free:** 800.565.4801  
**Int'l:** +1.416.960.9900



## Jellyfish® Filter Quick Glance

The Jellyfish® Filter is an engineered Stormwater quality treatment technology featuring pre-treatment and membrane filtration in a compact stand-alone treatment system that removes a high level and wide variety of Stormwater pollutants. Exceptional pollutant removal is achieved at high treatment flow rates with minimal head loss and low maintenance costs. Each lightweight Jellyfish Filter cartridge contains an extraordinarily large amount of membrane surface area resulting in superior flow capacity and pollutant removal capacity.

**Jellyfish Filter efficiently captures a high level of stormwater pollutants, including:**

### **Pollutant Removal\***

- ✓ Total Suspended Solids (TSS), median removal efficiency of 89%, including particles less than 2 microns
- ✓ Suspended Solids Concentration (SSC) 99%
- ✓ Total Nitrogen (TN), median removal efficiency of 51%
- ✓ Total Phosphorus (TP), median removal efficiency of 59%
- ✓ Total Copper (Cu), median removal efficiency of 90%
- ✓ Total Zinc (Zn), median removal efficiency of 70%
- ✓ Free Oil
- ✓ Floatable trash and debris 100%

\* Based on 3<sup>rd</sup> party field testing

Jellyfish Filter field test performance results have been verified by the New Jersey Corporation for Advanced Technology (NJCAT), through the TARP Program.

Jellyfish cartridges are passively backwashed automatically after each storm event, which removes accumulated sediment from the membranes and significantly extends the service life of the cartridges and the maintenance interval. If required, the cartridges can be easily manually backwashed without removing the cartridges. Additionally, the lightweight cartridges can be removed by hand and externally rinsed, and rinsed cartridges then re-installed. These simple maintenance options allow for cartridge regeneration, thereby minimizing cartridge replacement costs and life-cycle treatment costs while ensuring long-term treatment performance.

## Jellyfish® Filter Patent Information

Jellyfish® Filter patent information: U.S. Patent No. 8,123,935; Other U.S. Patents Pending; International Patents Pending



# Table of Contents

## Chapter 1

1.0 Imbrium Systems Contact Information.....	1
--	---

## Chapter 2

2.0 Jellyfish Filter Design Overview.....	1
2.1 Jellyfish Filter Description .....	1
2.2 Jellyfish Filter Membrane Filtration Cartridge.....	4
2.3 Jellyfish Filter Operation – Driving Head Requirement.....	6
2.4 Jellyfish Filter Operation – Treatment Functions.....	7
2.5 Jellyfish Filter Operation – Self-Cleaning Functions.....	9

## Chapter 3

3.0 Jellyfish Filter Design Guidelines.....	10
3.1 Configurations and Design Capacities.....	10
3.2 Inlet and Outlet Pipes.....	12
3.3 Bypass Design.....	16
3.4 Shallow or Low Cover Installations.....	16
3.5 Submerged Installations.....	16
3.6 Grated Inlet and Curb Inlet Jellyfish Filters.....	16
3.7 Series Jellyfish Filter.....	17
3.8 Jellyfish Filter with Sump Drain.....	17

## Chapter 4

4.0 Jellyfish Filter Sizing Guidelines.....	17
4.1 Sizing for Water Quality Treatment Flow Rate.....	17
4.2 Sizing for Sediment Mass Loading.....	17
4.3 Continuous Simulation Sizing Tool.....	19

## Chapter 5

5.0 Jellyfish Filter Installation.....	19
--	----

## Chapter 6

6.0 Jellyfish Filter Inspection and Maintenance.....	20
--	----

## Chapter 7

7.0 Jellyfish Filter Replacement Parts.....	21
---	----

## Chapter 8

8.0 Jellyfish Filter Performance Specification.....	21
---	----



# Table of Contents

## List of Figures

Figure 1.....	4
Jellyfish Filter and Components	
Figure 2.....	5
Jellyfish Membrane Filtration Cartridge	
Figure 3.....	7
Jellyfish Filter Treatment Functions	
Figure 4.....	13
Jellyfish Configuration with Below-Deck Inlet Pipe	
Figure 5.....	14
Jellyfish Configuration with Above-Deck Inlet Pipe	

## List of Tables

<b>Table 1</b> .....	11
Design Flow Capacities of Standard Jellyfish Filter Manhole Configurations	
<b>Table 2</b> .....	12
Design Pollutant Capacities of Standard Jellyfish Filter Manhole Configurations	
<b>Table 3</b> .....	15
Minimum Inlet and Outlet Pipe Separation Angles and Diameters	
<b>Table 4</b> .....	18
Dry Weight, Treatment Flow Rate, and Sediment Mass Loading Capacity of Various Cartridge Lengths	
<b>Table 5</b> .....	19
Annual Total Suspended Solids Load by Land Use	



# Table of Contents

## Appendix A

**A**

### Jellyfish® Filter Standard Drawings - U.S. Customary Units

Jellyfish Filter Typical Layout.....	A1
Jellyfish Filter JF4.....	A2 - A3
Jellyfish Filter JF6.....	A4 - A5
Jellyfish Filter JF8.....	A6 - A7
Jellyfish Filter JF10.....	A8 - A9
Jellyfish Filter JF12.....	A10 - A11
Jellyfish Filter for Shallow Applications (with Hatch).....	A12 - A13
Offline Jellyfish Filter with Grated Inlet.....	A14 - A15
Offline Jellyfish Filter with Curb Inlet.....	A16 - A17
Online Jellyfish Filter with Grated or Curb Inlet showing Optional Hood.....	A18
Jellyfish Filter with Sump Drain.....	A19
Fiberglass Jellyfish Filter.....	A20 - A21

## Appendix B

**B**

### Jellyfish Filter Standard Specifications – Water Quality Filter Treatment Device

Part 1 - General.....	B1
Part 2 - Products.....	B1
Part 3 - Performance.....	B4
Part 4 - Execution.....	B5
Part 5 - Quality Assurance.....	B6

## Appendix C

### Jellyfish Filter Design Form

**C**

Design Form.....	C1
------------------	----



Notes





# Chapter 1

## 1.0 Imbrium® Systems Contact Information

Imbrium® Systems is an engineered stormwater treatment company that designs, develops, manufactures, and distributes post-construction stormwater quality treatment technologies, to protect water resources from pollutants. Imbrium has a strong record of environmental innovation in the industry as the creator of the Stormceptor® oil and sediment separator, the Jellyfish® Filter, Sorbtive®MEDIA, Sorbtive®FILTER, and Sorbtive®VAULT.

Imbrium Systems is a global company with U.S. headquarters (Imbrium Systems Corporation) located in Rockville, Maryland and Canadian and International headquarters (Imbrium Systems Incorporated and Imbrium International Limited) located in Toronto, Ontario, Canada.

The Jellyfish® Filter is represented by a variety of licensees and organizations globally.

**For assistance, please contact Imbrium Systems at:**

**United States:** 888-279-8826 or 301-279-8827

**Canada / International:** 800-565-4801 or 416-960-9900

# Chapter 2

## 2.0 Jellyfish Filter Design Overview

This technical manual provides information for design and installation of the Jellyfish Filter. When designed properly in accordance with this Technical Manual, the Jellyfish Filter will exceed the performance and longevity of conventional horizontal bed and granular media filters.

Test data is available from Imbrium Systems upon request.

## 2.1 Jellyfish Filter Description

The Jellyfish Filter is an engineered stormwater quality treatment technology featuring unique membrane filtration in a compact stand-alone treatment system that removes a high level and wide variety of storm-water pollutants. Exceptional pollutant removal is achieved at high treatment flow rates with minimal head loss and low maintenance costs. Each lightweight Jellyfish Filter cartridge consists of multiple membrane-encased filter elements (“filtration tentacles”) attached to a cartridge head plate. The filtration tentacles provide an extraordinarily large amount of surface area, resulting in superior flow capacity and suspended sediment removal capacity.

Jellyfish efficiently captures a high level of stormwater pollutants, including:

### **Pollutant Removal\***

- Total Suspended Solids (TSS), median removal efficiency of 89%, including particles less than 2 microns
- Suspended Solids Concentration (SSC) 99%



- Total Nitrogen (TN), median removal efficiency of 51%
- Total Phosphorus (TP), median removal efficiency of 59%
- Total Copper (Cu), median removal efficiency of 90%
- Total Zinc (Zn), median removal efficiency of 70%
- Free Oil
- Floatable trash and debris 100%

\* Based on 3rd party field testing

Jellyfish Filter field test performance results have been verified by the New Jersey Corporation for Advanced Technology (NJCAT), through the TARP Program.

Jellyfish cartridges are passively backwashed automatically after each storm event, which removes accumulated sediment from the membranes and significantly extends the service life of the cartridges and the maintenance interval. If required, the cartridges can be easily manually backwashed without removing the cartridges. Additionally, the light-weight cartridges can be removed by hand and externally rinsed, and rinsed cartridges then re-installed. These simple maintenance options allow for cartridge regeneration, thereby minimizing cartridge replacement costs and life-cycle treatment costs while ensuring long-term treatment performance.

The Jellyfish Filter is comprised of several structural and functional components:

- A **cylindrical (manhole) or rectangular structure** constructed of either precast concrete or fiberglass, and available in a wide variety of sizes and configurations, serves as a vessel that provides long-lasting structural support for the system; provides hydraulic connections to the inlet and outlet pipes; provides surfaces for structural attachment of the cartridge deck and maintenance access wall; provides influent water storage and flow-through volume for pollutant separation and membrane filtration treatment; and provides a high-volume sump for storage of accumulated sediment.
- A rigid high-strength fiberglass **cartridge deck** separates the vessel into a lower chamber and upper chamber; houses the filter cartridges; provides a surface and flow path for treated water to the effluent pipe; provides double-wall containment of oil and other hydrocarbons below deck; and provides a platform for maintenance personnel to safely service the filter cartridges. The lower chamber provides influent water storage and flow-through volume for pollutant separation and membrane filtration treatment, and storage of accumulated sediment. The upper chamber provides above-deck clearance for inspection and maintenance service. The cartridge deck is securely attached to the vessel wall.
- A rigid high-strength fiberglass **maintenance access wall** attenuates influent water velocity; channels influent water into the lower chamber via a large opening in the cartridge deck; provides storage volume for floatable pollutants; and serves as a convenient inspection and maintenance access point for pollutant removal.
- **Cartridge receptacles** are secured to the cartridge deck and together with the cartridge lids, serve to securely anchor the filter cartridges into the cartridge deck.



- **Jellyfish membrane filtration cartridges** are inserted into the cartridge receptacles and secured with the cartridge lids. The filter cartridges treat the influent stormwater by filtering out fine suspended particulates (TSS) and particulate-bound pollutants on the membrane of each filtration tentacle. Filtered water passes through the membranes, flows up the center tube of each filtration tentacle and exits the top opening of each tentacle. Cartridges are available in various lengths and flow ratings. Filter cartridges are designated as either **hi-flo cartridges** or **draindown cartridges**, depending on their placement position within the cartridge deck. Cartridges placed within the backwash pool weir are automatically passively backwashed after each storm event, and are designated the hi-flo cartridges. Cartridges placed outside the backwash pool weir are not passively backwashed but facilitate the draindown of the backwash pool and these are designated the draindown cartridges. The design flow rate of a draindown cartridge is controlled by a cartridge lid orifice to one-half the design flow rate of a hi-flo cartridge of similar length. The lower design flow rate of the draindown cartridge reduces the likelihood of occlusion prior to scheduled maintenance.
- **Cartridge lids** are fastened onto the cartridge receptacles to securely anchor the filter cartridges into the cartridge deck. The lids are removable to allow manual backflushing or removal of the filter cartridges when required during maintenance service. Cartridge lids contain a **flow control orifice** that is specifically sized for use with hi-flo and draindown cartridges. **Blank lids** have no orifice and are used to cover unoccupied cartridge receptacles in systems that do not use the full rated flow capacity of the system.
- A **separator skirt** serves as a baffle that encloses the filtration tentacles and defines the filtration zone inside the separator skirt perimeter. The separator skirt extends the full length of the filtration tentacles and prevents contamination of the membranes with oil and floatable debris. The separator skirt has a large opening at the bottom that allows pre-treated water to enter the filtration zone under low velocity. The separator skirt is securely attached to the underside of the cartridge deck.
- A rigid fiberglass **backwash pool weir** extends 6 inches (150 mm) above the cartridge deck and encloses the hi-flo cartridges. During inflow, filtered water exiting the hi-flo cartridges forms a pool inside the weir. If sufficient driving head is available the pool overtops the weir and spills to the cartridge deck where it subsequently flows to the outlet pipe. As the inflow event subsides and forward driving head decreases, water in the backwash pool reverses flow direction and automatically passively backwashes the hi-flo cartridges, cleaning the membrane surfaces. Water in the lower chamber (below deck) is displaced through the draindown cartridges. This self-cleaning mechanism may occur multiple times during a single storm event as rainfall/runoff intensities rise and fall, thereby significantly extending the service life of the cartridges and the maintenance interval.
- **Optional internal bypass pressure relief pipe(s)** can be placed in one or multiple cartridge receptacles. The pressure relief pipe height and diameter can be varied to accommodate the design peak flow rate and system driving head requirements. When the internal bypass option is utilized, peak flow rates receive membrane filtration treatment up to the filtration design flow rate, with the balance of the peak flow receiving pre-treatment.
- A **deflector plate** (below-deck inlet pipe manhole configuration only) is installed across the below-deck inlet pipe opening to induce tangential water flow through the pre-treatment channel between the vessel wall and separator skirt.
- **Standard covers, rectangular hatches, or inlet grates** are installed at the surface and are removed to allow maintenance access to the system.
- **Built-in steps or ladder(s)** allow maintenance personnel to access the cartridge deck and filter cartridges.

The Jellyfish Filter and components are depicted in **Figure 1**.

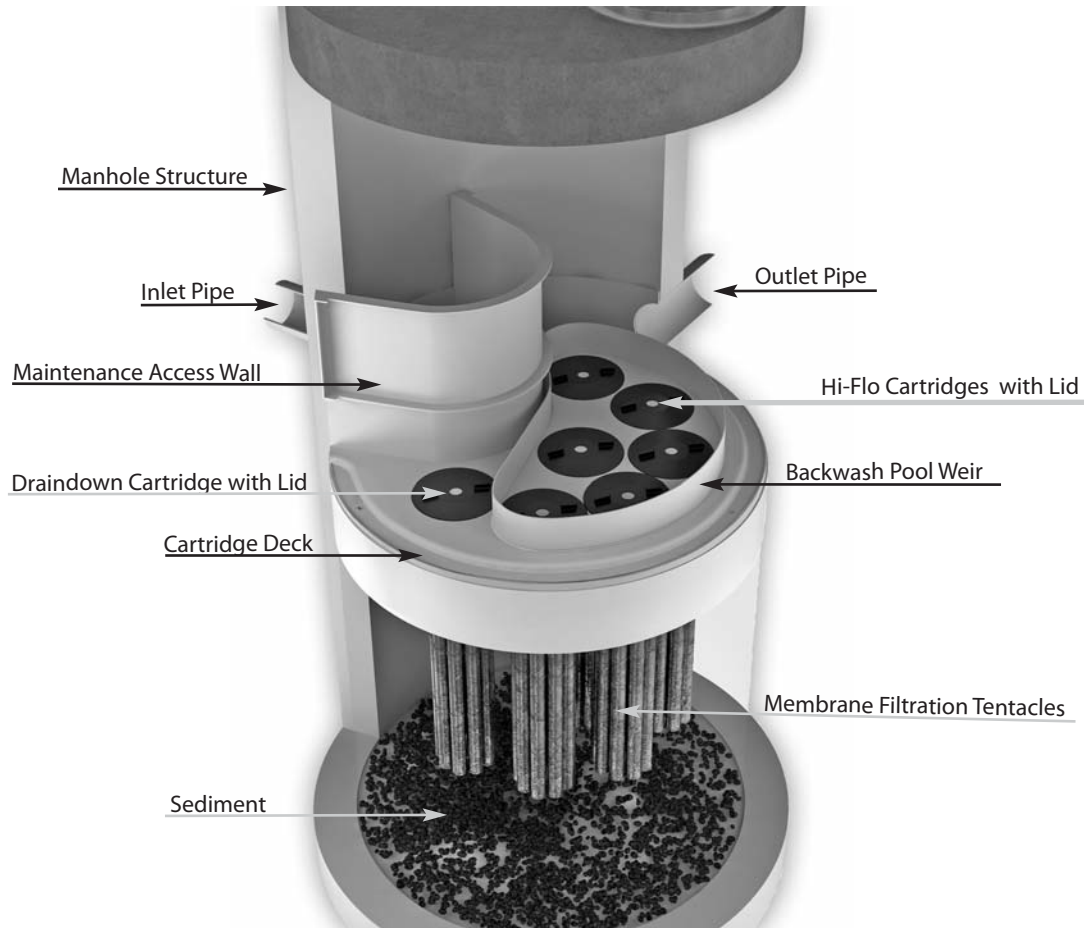

**FIGURE 1****Jellyfish Filter and Components**

**Note:** Separator Skirt Not Shown

## 2.2 Jellyfish Membrane Filtration Cartridge

The Jellyfish Filter utilizes multiple lightweight membrane filtration cartridges. Each cartridge consists of multiple removable filter elements (“filtration tentacles”) attached to a cartridge head plate. Each filtration tentacle consists of a central perforated tube surrounded by a specialized membrane. The cylindrical filtration tentacle has a threaded pipe nipple at the top and is sealed at the bottom with an end cap. A cluster of tentacles is attached to a stainless steel head plate by inserting the top pipe nipples through the head plate holes and securing with removable nuts. A removable oil-resistant polymeric rim gasket is attached to the head plate to impart a watertight seal when the cartridge is secured into the cartridge receptacle with the cartridge lid. A Jellyfish membrane filtration cartridge is depicted in **Figure 2**.

The cartridge is available in a variety of lengths. The cartridge weight, treatment flow rate, and sediment mass loading capacity will vary depending on the cartridge length, as depicted in **Table 4**. The dry weight of a new cartridge is less than 25 pounds (11.4 kg) and the wet weight of a used cartridge is less than 50 pounds (23 kg), making a cartridge easy to install and remove by hand. No heavy lifting equipment is required.

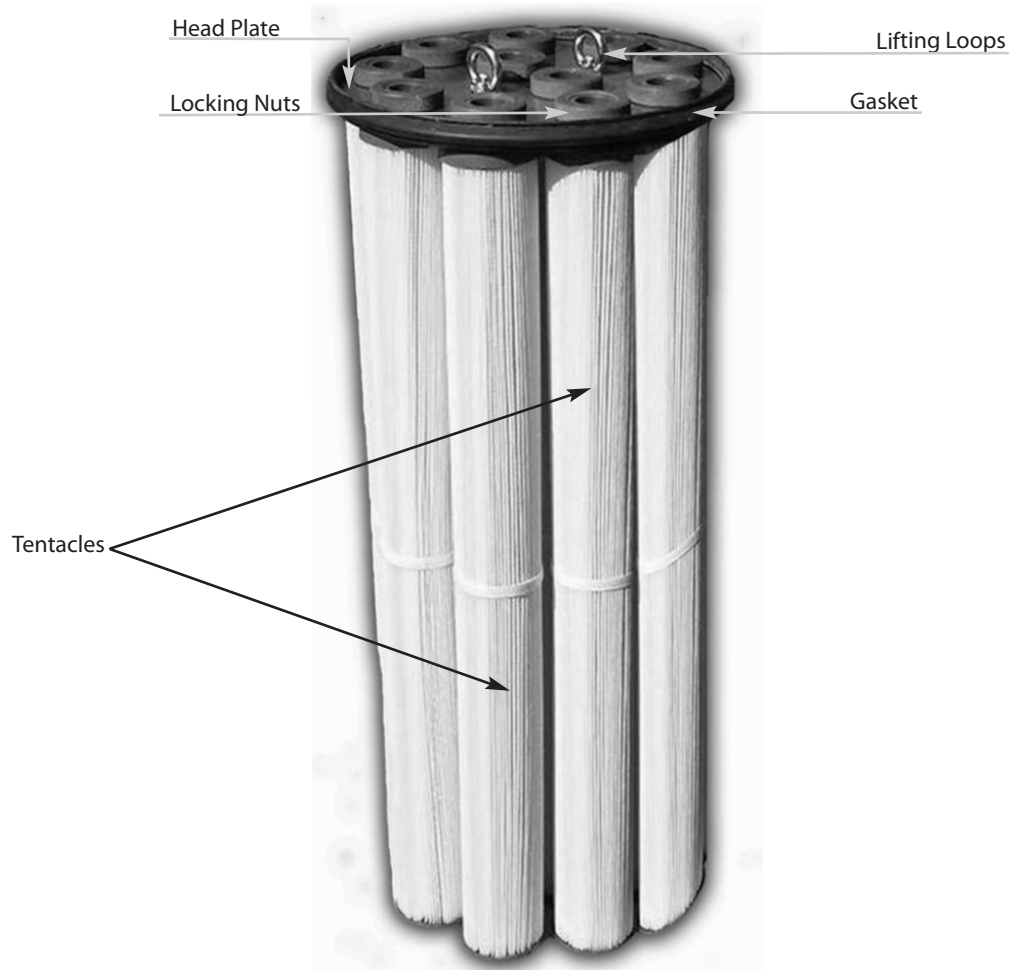

**FIGURE 2****Jellyfish Membrane Filtration Cartridge**

The filtration tentacle membranes provide an extraordinarily large amount of surface area, resulting in superior flow capacity and suspended sediment removal capacity. A typical Jellyfish cartridge with eleven 54-inch (1372 mm) long filtration tentacles has 381 ft<sup>2</sup> (35.4 m<sup>2</sup>) of membrane surface area. Hydraulic testing on a clean 54-inch (1372 mm) filter cartridge has demonstrated a flow rate of 180 gpm (11.3 L/s) at 18 inches (457 mm) of driving head.

Extensive third-party field testing, including testing at an urban site with very high intensity rainfall and runoff, has demonstrated consistently high pollutant removal performance with a conservative design flow rate of 80 gpm (5.0 L/s) for the 54-inch (1372 mm) long hi-flo cartridge and 40 gpm (2.5 L/s) for the 54-inch (1372 mm) long draindown cartridge. These values translate to a conservative design membrane filtration flux rate (flow per unit surface area) of 0.21 gpm/ft<sup>2</sup> (0.14 Lps/m<sup>2</sup>) for the hi-flo cartridge and 0.11 gpm/ft<sup>2</sup> (0.07 Lps/m<sup>2</sup>) for the draindown cartridge.

The standard membrane demonstrates removal of >85% of fine sediment at a design flux rate of 0.21 gpm/ft<sup>2</sup>, based on laboratory testing with Sil-Co-Sil™106 which has a median particle size (d50) of 22 microns.



Hydraulic and sediment loading testing has demonstrated scalability of the membrane filtration surface area such that increases in the number and/or length of filtration tentacles contribute a uniform increase in total filter surface area and therefore flow capacity and sediment removal capacity. The flow rating of a particular Jellyfish Filter cartridge is based on the membrane filtration surface area of the cartridge and data collected from both laboratory testing and field testing.

The cartridge deck contains a receptacle for each filter cartridge. The cartridge is lowered down into the receptacle such that the cartridge head plate and rim gasket rest on the lip of the receptacle. A cartridge lid is fastened onto the receptacle to anchor the cartridge. Each cartridge lid contains a flow control orifice. The orifice in the hi-flo cartridge lid is larger than the orifice in the draindown cartridge lid.

Jellyfish Filter cartridges are designated as either hi-flo cartridges or draindown cartridges, depending on their placement position within the cartridge deck. Cartridges placed within the 6-inch (150 mm) high backwash pool weir that extends above the deck are automatically passively backwashed after each storm event and are designated as the hi-flo cartridges. Cartridges placed outside the backwash pool weir are not passively backwashed but facilitate the draindown of the backwash pool, and these are designated as the draindown cartridges. The design flow rate of a draindown cartridge is controlled by a cartridge lid orifice to one-half the design flow rate of a hi-flo cartridge of similar length. The lower design flow rate of the draindown cartridge reduces the likelihood of occlusion prior to scheduled maintenance.

Inflow events with driving head ranging from less than 1 inch (25 mm) up to the maximum design driving head will cause continuous forward flow and filtration treatment through the draindown cartridges. Inflow events with driving head that exceeds the 6-inch (150 mm) height of the backwash pool weir will cause continuous forward flow and filtration treatment through the hi-flo cartridges.

### 2.3 Jellyfish Filter Operation – Driving Head Requirement

A differential in upstream and downstream water elevation during an inflow event provides the minimal driving head required to overcome the minor cumulative friction loss through the system, at which point flow-through operation of the Jellyfish Filter commences.

For systems using an external bypass with upstream diversion structure, the driving head is calculated as the difference in elevation between the top of the diversion structure weir and the invert of the Jellyfish Filter outlet pipe. For systems using an internal bypass, the driving head is calculated as the difference in elevation between the top of the pressure relief pipe(s) and the invert of the outlet pipe.

A minimum design driving head is selected to achieve design flow rates, while accounting for gradual increase in system head loss at the design flow rate due to long-term accumulation of sediment on the filtration membranes. A clean Jellyfish Filter cartridge has flow capacity far in excess of the cartridge design flow rate at the design driving head. This ensures that design flow capacity is maintained during the period between maintenance service operations.

Typically, a minimum 18 inches (457 mm) of driving head is designed into the system but may vary from 12 to 24 inches (305 to 610 mm) depending on specific site requirements.



For systems that may experience submerged or backwater conditions due to dry weather base flow or tidal effects, driving head calculations must account for water elevation during the backwater condition. The Jellyfish Filter treatment functions will continue to operate during forward flow despite backwater conditions. An increase in the maintenance access wall height may be required to ensure floatables capture an increase in the height of the backwash pool weir may be required to ensure function of the automatic passive backwash feature.

## 2.4 Jellyfish Filter Operation – Treatment Functions

The Jellyfish Filter provides both **pre-treatment** and **membrane filtration** treatment to remove pollutants from stormwater runoff. These functions are depicted in **Figure 3** below.

**FIGURE 3**

### Jellyfish Filter Treatment Functions Pre-Treatment and Membrane Filtration Section View with Maintenance Access Wall (MAW) Cutaway

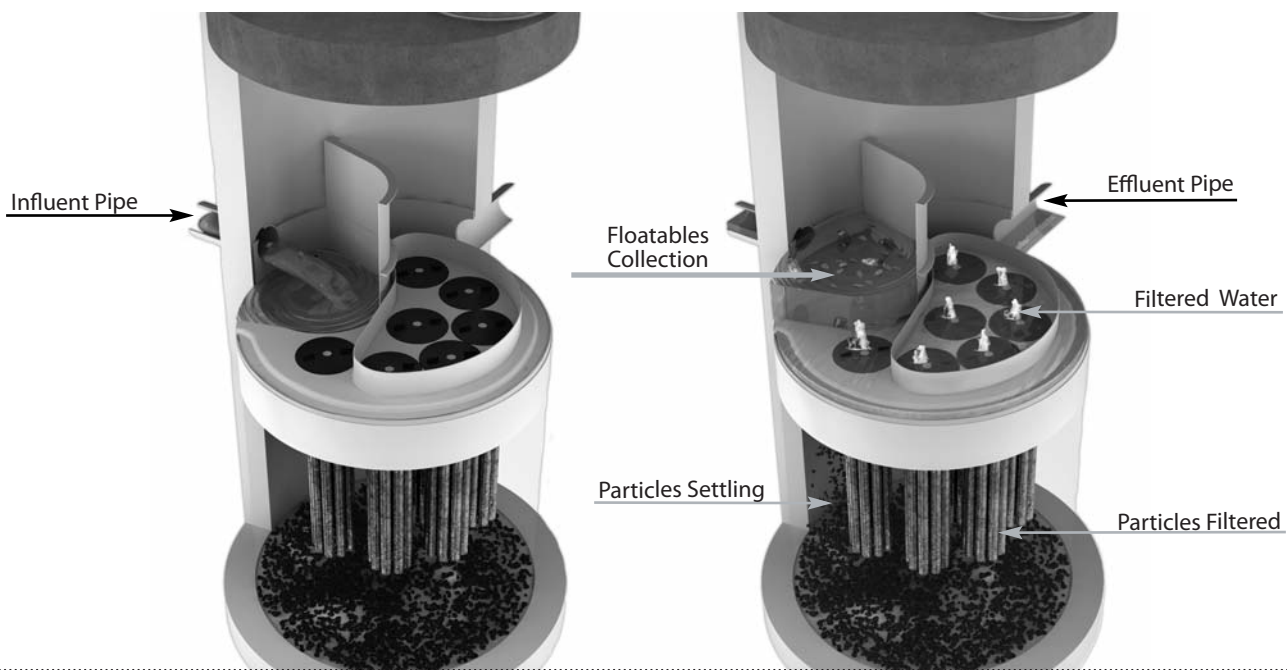

**Pre-treatment** removes coarse sediment (generally > 50 microns), particulate-bound pollutants attached to coarse sediment (nutrients, toxic metals, hydrocarbons), free oil and floatable trash and debris. These pollutants are removed by gravity separation. Large, heavy particles fall to the sump (sedimentation) and low density pollutants rise to the surface (floatation) within the pre-treatment channel.

Pre-treatment begins when influent flow enters the system either through an above-deck inlet pipe (standard) or below-deck inlet pipe (optional). In the above-deck inlet pipe configuration, influent enters the maintenance access wall zone and is channeled through a large-diameter opening in the cartridge deck to the lower chamber. The large surface area of the deck opening and change in flow direction attenuate the influent flow velocity. Due to equalization of hydrostatic pressure and downstream pathway through the opening at the bottom of the separator skirt, influent flow spreads in lateral and downward directions throughout the pre-treatment channel between the vessel wall and the outer perimeter of the separator skirt. In the below-deck inlet pipe configuration, a deflector plate angled across the inlet pipe opening induces directional tangential flow in the pre-treatment channel. In either configuration, flow spreading throughout the pre-treatment channel serves to reduce the average flow velocity and enhance the separation of pollutants.

Pre-treatment for floatables occurs as buoyant pollutants rise toward the surface, with some of the floatables mass trapped beneath the cartridge deck in the pre-treatment channel. Most of the floatables mass accumulating in the maintenance access wall zone at the air-water interface. This feature allows convenient and easy inspection and maintenance for floatable contaminants. The separator skirt protects the filtration tentacles from contamination by oil and floatable debris.

Coarse sediment settles out of the pre-treatment channel to the sump. As water from the pre-treatment channel slowly flows downward and then laterally beneath the separator skirt, the combination of the large opening in the bottom of the separator skirt and a change in direction to an upward downstream flow path serves to further reduce average flow velocity and enhance particle separation. Sediment is stored in the sump until removed by vacuum during a maintenance service.

**Membrane filtration treatment** removes suspended particulates (generally < 50 microns) and particulate-bound pollutants (nutrients, toxic metals, hydrocarbons, and bacteria). Laboratory and field performance testing of the Jellyfish Filter have demonstrated capture of particulates as small as 2 microns.

Filtration treatment begins when pre-treated influent flows under the separator skirt and into the filtration zone through the large opening defined by the bottom edge of the separator skirt. Uniform hydraulic pressure gradient across the entire membrane surface area causes pre-treated water to penetrate the entire membrane surface area of each filtration tentacle. Water enters the membrane pores radially and deposits fine particulates on the exterior membrane surface. Filtered water flows into the perforated center drain tube of each filtration tentacle and then upward and out the top of each tentacle. Water exiting each of the tentacles of a single cartridge combines at the top of the cartridge under the cartridge lid. The combined flow then vertically exits the cartridge lid orifice with a pulsating fountain effect.





As a layer of sediment builds up on the external membrane surface, membrane pores are partially occluded which serves to reduce the effective pore size. This process, referred to as “filter ripening”, significantly improves the removal efficiency of pollutants relative to a brand new or clean membrane of some nominal pore size. Filter ripening accounts for the ability of the JellyfishF filter to remove particles finer than the nominal pore size rating of the membranes.

Jellyfish Filter operation and maintenance information can be obtained from the Jellyfish Filters Owner's Manual on Imbrium Systems website ([www.imbriumsystems.com](http://www.imbriumsystems.com)).

## 2.5 Jellyfish Filter Operation – Self-Cleaning Functions

The Jellyfish Filter utilizes several self-cleaning processes to remove accumulated sediment from the external surfaces of the filtration membranes, including **automatic passive backwash** of the hi-flo cartridges, **vibrational pulses**, and **gravity**. Combined, these processes significantly extend the cartridge service life, maintenance interval and reduce life-cycle costs.

**Automatic passive backwash** is performed on the hi-flo cartridge at the end of each runoff event and can also occur multiple times during a single storm event as intensity and driving head varies. During inflow, filtered water exiting the hi-flo cartridges forms a pool above the cartridge deck inside the backwash pool weir. The depth and volume of the backwash pool will vary with the available driving head, ranging from some minimal quantity up to a quantity sufficient to fill and overflow the backwash pool (typical weir height is 6 inches / 150 mm). As the inflow event subsides and forward driving head decreases, water in the backwash pool reverses flow direction and automatically passively backwashes the hi-flo cartridges, removing sediment from the membrane surfaces. Water in the lower chamber (below deck) is displaced through the draindown cartridges.

**Vibrational pulses** occur as a result of complex and variable pressure and flow direction conditions that arise in the space between the top surface of the cartridge head plate and the underside of the cartridge lid. During forward flow a stream of filtered water exits the top of each filtration tentacle into this space and encounters resistance from the cartridge lid and turbulent pool of water within the space. Water is forced through the cartridge lid flow control orifice with a pulsating fountain effect. The variable localized pressure causes pulses that transmit vibrations to the membranes, thereby dislodging accumulated sediment. The effect appears more pronounced at higher flow rates, and applies to both hi-flo and draindown cartridges.

**Gravity** continuously applies a force to accumulated sediment on the membranes, both during inflow events and inter-event dry periods. As fine particles agglomerate into larger masses on the membrane surface, adhesion to the membrane surface can lessen, and a peeling effect ensues which ultimately results in agglomerates falling away from the membrane. Complex chemical and biological effects may also play a role in this process.



## Chapter 3

### 3.0 Jellyfish Filter Design Guidelines

The Jellyfish Filter has many flexible design features to accommodate a wide range of specific site requirements and constraints. For design assistance, please contact Imbrium Systems.

### 3.1 Configurations and Design Capacities

Design flow capacities and pollutant capacities for standard Jellyfish Filter manhole configurations are shown in **Tables 1 and 2**.

The Jellyfish Filter standard model numbers provide information about the manhole inside diameter (expressed in U.S. customary units) and cartridge counts for hi-flo and draindown cartridges. For example, Jellyfish Filter Model Number JF6-4-1 is a 6-ft (1.8 m) diameter manhole with four hi-flo cartridges and one draindown cartridge. Standard model numbers assume the use of 54-inch (1372 mm) long cartridges. Specific designations for non-standard structures or cartridge lengths are noted in the **Jellyfish Filter Owner's Manual**.



**Table 1**  
**Design Flow Capacities**  
**Standard Jellyfish Filter Manhole Configurations**

Manhole Diameter (ft / m) <sup>1</sup>	Model No.	Hi-Flo Cartridges <sup>2</sup> 54 in / 1372 mm	Draindown Cartridges <sup>2</sup> 54 in / 1372 mm	Design Treatment Flow Rate (gpm / cfs)	Design Treatment Flow Rate (L / S)
<b>4 / 1.2</b>	<b>JF4-2-1</b>	<b>2</b>	<b>1</b>	<b>200 / 0.45</b>	<b>12.6</b>
<b>6 / 1.8</b>	<b>JF6-3-1</b>	<b>3</b>	<b>1</b>	<b>280 / 0.62</b>	<b>17.7</b>
	JF6-4-1	4	1	360 / 0.80	22.7
	JF6-5-1	5	1	440 / 0.98	27.8
	JF6-6-1	6	1	520 / 1.16	32.8
<b>8 / 2.4</b>	<b>JF8-6-2</b>	<b>6</b>	<b>2</b>	<b>560 / 1.25</b>	<b>35.3</b>
	JF8-7-2	7	2	640 / 1.43	40.4
	JF8-8-2	8	2	720 / 1.60	45.0
	JF8-9-2	9	2	800 / 1.78	50.5
	JF8-10-2	10	2	880 / 1.96	55.5
<b>10 / 3.0</b>	<b>JF10-11-3</b>	<b>11</b>	<b>3</b>	<b>1000 / 2.23</b>	<b>63.1</b>
	JF10-12-3	12	3	1080 / 2.41	68.1
	JF10-12-4	12	4	1120 / 2.50	70.7
	JF10-13-4	13	4	1200 / 2.67	75.7
	JF10-14-4	14	4	1280 / 2.85	80.8
	JF10-15-4	15	4	1360 / 3.03	85.8
	JF10-16-4	16	4	1440 / 3.21	90.8
	JF10-17-4	17	4	1520 / 3.39	95.9
	JF10-18-4	18	4	1600 / 3.56	100.9
	JF10-19-4	19	4	1680 / 3.74	106
<b>12 / 3.6</b>	<b>JF12-20-5</b>	<b>20</b>	<b>5</b>	<b>1800 / 4.01</b>	<b>113.6</b>
	JF12-21-5	21	5	1880 / 4.19	118.6
	JF12-22-5	22	5	1960 / 4.37	123.7
	JF12-23-5	23	5	2040 / 4.54	128.7
	JF12-24-5	24	5	2120 / 4.72	133.8
	JF12-25-5	25	5	2200 / 4.90	138.8
	JF12-26-5	26	5	2280 / 5.08	143.8
	JF12-27-5	27	5	2360 / 5.26	148.9

<sup>1</sup> Smaller and larger systems may be custom designed

<sup>2</sup> Shorter length cartridge configurations are available



<b>Model Diameter (ft / m)</b>	<b>Wet Volume Below Deck (ft<sup>3</sup> / m<sup>3</sup>)</b>	<b>Sediment Capacity<sup>1</sup> (ft<sup>3</sup> / m<sup>3</sup>)</b>	<b>Oil Capacity<sup>2</sup> (gal / L)</b>
<b>JF4</b>			
4 / 1.2	82 / 2313	12 / 0.34	100 / 379
<b>JF6</b>			
6 / 1.8	184 / 5205	28 / 0.79	224 / 848
<b>JF8</b>			
8 / 2.4	327 / 9252	50 / 1.42	388 / 1469
<b>JF10</b>			
10 / 3.0	511 / 14,456	78 / 2.21	608 / 2302
<b>JF12</b>			
12 / 3.6	735 / 20,820	113 / 3.20	732 / 2771

<sup>1</sup> Assumes 12 inches (305 mm) of sediment depth in sump  
Systems may be designed with increased sediment capacity

<sup>2</sup> Assumes 24 inches (610 mm) of pre-treatment channel depth for oil storage

### 3.2 Inlet and Outlet Pipes

The Jellyfish Filter is available in both the standard **above-deck inlet pipe** configuration and optional **below-deck inlet** pipe configuration. Specific site requirements generally determine the configuration that is most favorable for the site. For both configurations, the invert elevation of the outlet pipe is identical to the cartridge deck elevation. Please refer to **Figures 4 and 5**.



**FIGURE 4**

**Jellyfish Configuration  
with Below-Deck Inlet Pipe**

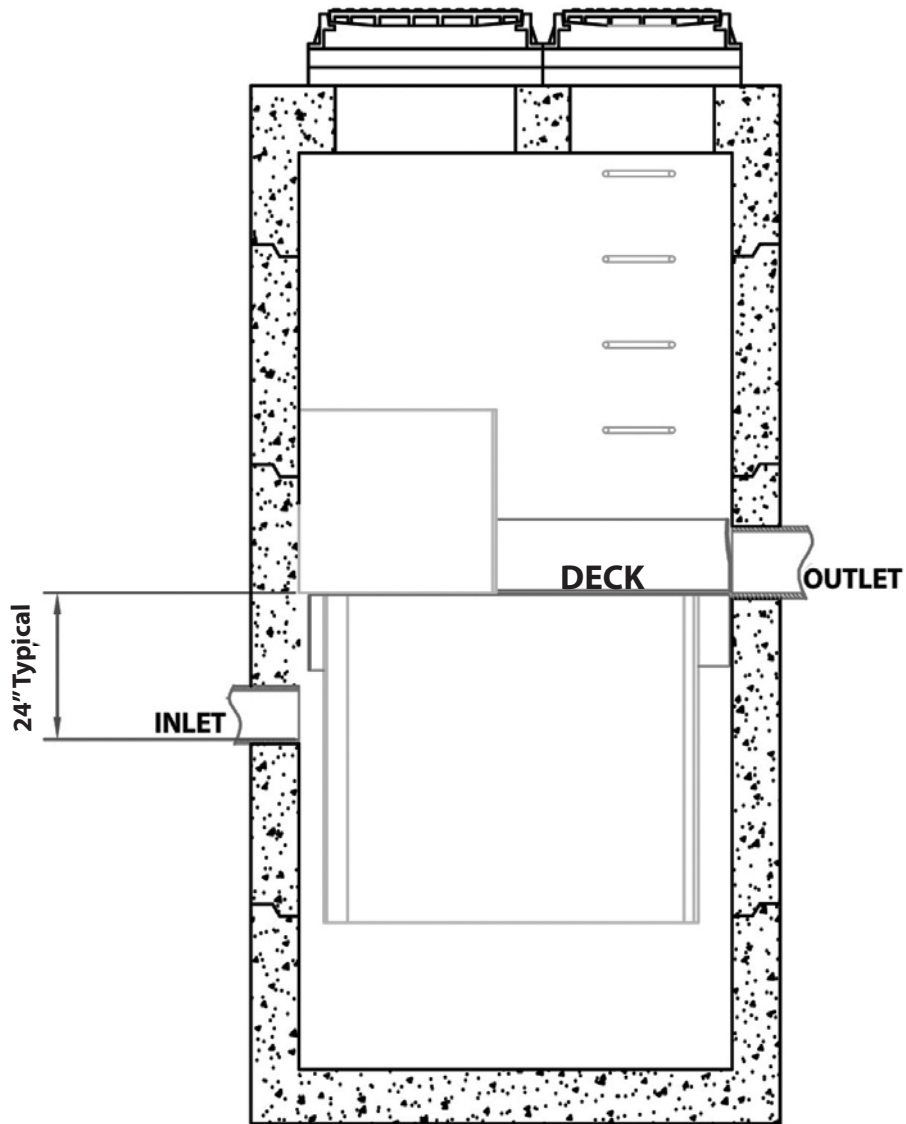

**FIGURE 5**

**Jellyfish Configuration  
with Above-Deck Inlet Pipe**

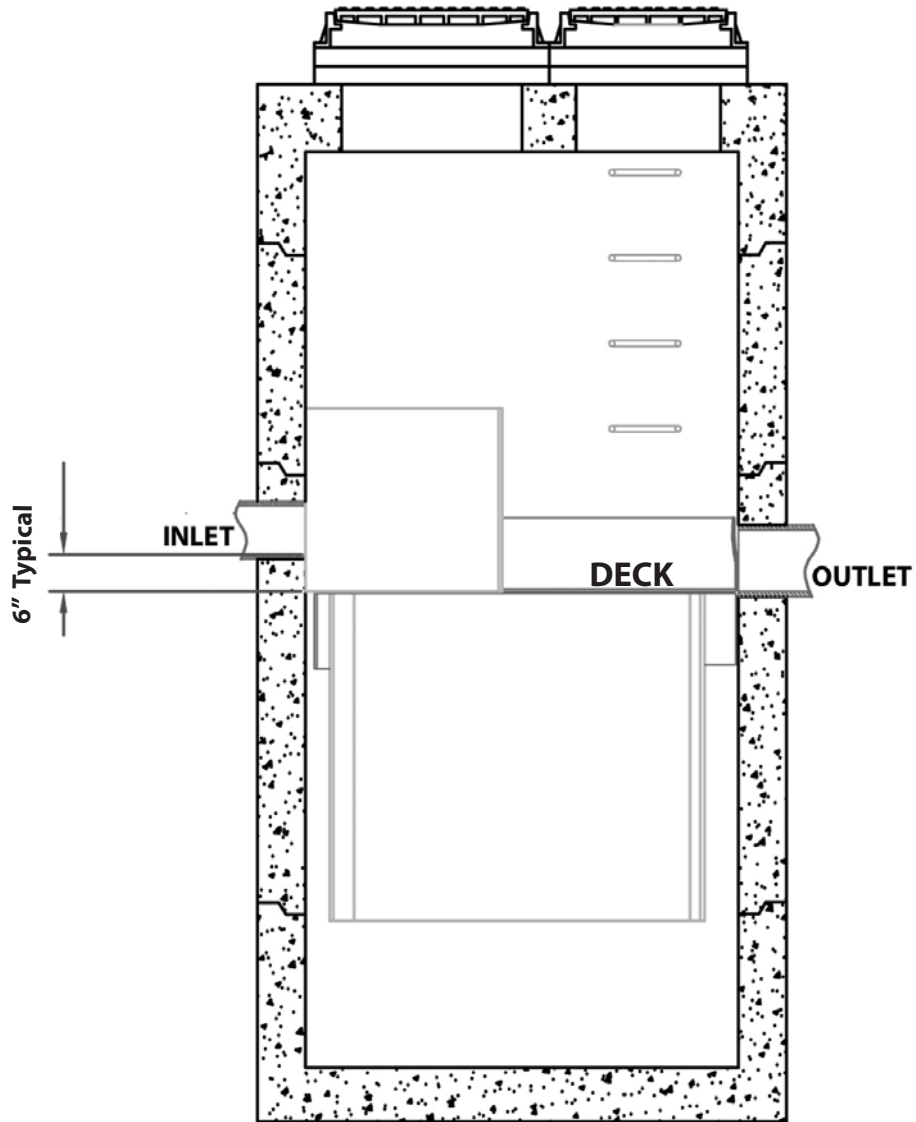

For the standard above-deck inlet pipe configuration, the invert elevation of the inlet pipe is typically set 6 inches (150 mm) higher than the invert elevation of the outlet pipe. This generally ensures that the inlet pipe will drain completely at the conclusion of each rainfall/runoff event, while providing sufficient volume within the maintenance access wall zone for surface accumulation of floatables below the inlet pipe. The elevation of the inlet pipe can be varied as required.

The Jellyfish Filter can accommodate a wide range of angles between the inlet and outlet pipes. The inlet pipe can be located anywhere about the circumference of the structure. The separation angle relationship of the inlet pipe to the outlet pipe can vary from 0 to 360 degrees to provide maximum design flexibility. Typical off-line layouts (external bypass using an upstream diversion structure) will have an inlet to outlet separation angle of 90 to 120 degrees. See **Table 3** below for the minimum separation angle for standard manhole configurations with an above-deck inlet pipe.

The Jellyfish Filter can accommodate **multiple inlet pipes** within certain restrictions.

The Jellyfish Filter can be built at all depths of cover generally associated with conventional stormwater conveyance systems.

<b>Model Diameter (ft / m)</b>	<b>Minimum Angle<sup>1</sup> Inlet / Outlet Pipes</b>	<b>Minimum Inlet Pipe Diameter (in / mm)</b>	<b>Minimum Outlet Pipe Diameter (in / mm)</b>
<b>JF4</b>			
4 / 1.2	62 °	6 / 152	8 / 203
<b>JF6</b>			
6 / 1.8	59 °	8 / 203	10 / 254
<b>JF8</b>			
8 / 2.4	52 °	10 / 254	12 / 305
<b>JF10</b>			
10 / 3.0	48 °	12 / 305	18 / 457
<b>JF12</b>			
12 / 3.6	40 °	12 / 305	18 / 457

<sup>1</sup> Assumes off-line (external bypass) configuration



### 3.3 Bypass Design

The Jellyfish Filter can be designed with either an off-line or on-line configuration. All stormwater filter systems will perform for a longer duration between required maintenance services when designed and applied in off-line configurations.

A standard off-line configuration has an external bypass that uses an upstream diversion structure. The elevation difference between the top of the diversion structure weir and the Jellyfish Filter outlet pipe invert establishes the design driving head associated with the design flow rate. Excess flow that overtops the diversion weir bypasses the Jellyfish Filter and proceeds downstream. Drawings that illustrate relative system elevations are available by contacting Imbrium Systems.

For some sites an off-line configuration may not be practical and use of an on-line configuration is advantageous. In these cases, an optional internal bypass pressure relief pipe(s) can be placed in one or multiple cartridge receptacles within the Jellyfish Filter. The pressure relief pipe height and diameter can be varied to accommodate the design peak flow rate and system driving head requirements. For these systems the driving head is calculated as the difference in elevation between the top of the pressure relief pipe and the invert of the outlet pipe. When the internal bypass option is utilized, peak flow rates receive membrane filtration treatment up to the filtration design flow rate, with the balance of the peak flow receiving pre-treatment. Increased sump depth may be required to increase sediment storage capacity and to minimize re-suspension of previously captured sediment at peak flow rates.

Please contact Imbrium Systems for design assistance.

### 3.4 Shallow or Low Cover Installations

For sites that require minimal depth of cover for the stormwater infrastructure, the Jellyfish Filter can be applied in a shallow application using a hatch cover to provide adequate access to all the cartridges within the unit. The general minimum depth of cover is 36 inches (915 mm) from the Jellyfish outlet pipe invert to the underside of the top slab. Further custom modifications may be possible. A typical drawing is included in **Appendix A**.

### 3.5 Submerged Installations

When properly designed, the Jellyfish Filter will function effectively under submerged conditions. For systems that may experience submerged or backwater conditions due to dry weather base flow or tidal effects, driving head calculations must account for water elevation during the backwater condition. The Jellyfish Filter treatment functions will continue to operate during forward flow despite backwater conditions. A customized increase to the maintenance access wall height may be required to ensure floatables capture and an increase in the height of the backwash pool weir may be required to ensure function of the automatic passive backwash feature.

### 3.6 Grated Inlet and Curb Inlet Jellyfish Filters

Existing drainage systems can be retrofitted by replacing conventional storm inlets with a Jellyfish Filter inlet. Imbrium Systems has two standard options, curb inlet and grated inlet configurations. Both configurations utilize





the shorter 27-inch (686 mm) length Jellyfish filter cartridges and require minimal cover. Two typical drawings are included in **Appendix A**. Further custom modifications may be possible.

### 3.7 Series Jellyfish Filter

For sites with water quality treatment flow rates that exceed the design flow rate of the largest standard Jellyfish Filter model, custom systems can be designed that hydraulically connect multiple Jellyfish Filters in series. Please contact Imbrium Systems for assistance.

### 3.8 Jellyfish Filter with Sump Drain

The Jellyfish Filter is typically designed to maintain a pool of water in the lower chamber (below deck) between storms. However, certain sites or jurisdictions may require draindown of the sump between storms. To meet these requirements, a sump drain filter can be installed to slowly drain the lower chamber pool to the sub-grade for infiltration or to an alternate point of discharge. A typical drawing is included in **Appendix A**.

## Chapter 4

### 4.0 Jellyfish Filter Sizing Guidelines

The Jellyfish Filter is sized based on considerations of the specified treatment flow rate, anticipated sediment mass load transported from the site and required pollutant storage capacities.

An optional software-based continuous simulation modeling tool, such as **PCSWMM for Stormceptor**<sup>®</sup>, can be utilized to determine site hydrology from local historical rainfall data and thereby assist in sizing a Jellyfish Filter. In general, such a tool is useful in deriving the water quality treatment flow rate associated with treatment of a high percentage of the average annual runoff volume.

#### 4.1 Sizing for Water Quality Treatment Flow Rate

The Jellyfish Filter can be sized using a specified flow rate (i.e. “water quality flow rate” or “treatment flow rate”). The treatment flow rate is determined by the engineer in accordance with methods approved by the local jurisdiction. The appropriate Jellyfish Filter model number is then selected from **Table 1**. Custom systems can be designed for sites with water quality treatment flow rates that exceed the design flow rate of the largest standard Jellyfish Filter model. Please contact Imbrium Systems for assistance.

#### 4.2 Sizing for Sediment Mass Loading

A second sizing consideration is the anticipated sediment load that will enter the Jellyfish Filter. For a stormwater filter system to have practical application in the field, it is important that the system’s sediment mass loading and storage



capacities permit a reasonable interval between successive maintenance clean-outs and filter cartridge service. It is recommended that a system be designed to accommodate a minimum one year interval between maintenance services for pollutant removal and filter cartridge flushing/rinsing.

Laboratory testing using a standard test sediment demonstrated sediment mass loading capacity of 125 pounds (57 kg) of sediment per 54-inch (1372 mm) long hi-flo cartridge at 18 inches (457 mm) of driving head (see **Table 4** below). Specific site conditions will influence the sediment mass loading capacity of the Jellyfish Filter due to the variable nature of sediment characteristics, rainfall intensity, time intervals between runoff events and frequency of automatic passive backwash.

The projected annual sediment load transported from the site should be determined by the engineer. Calculations can be performed for the projected annual runoff volume using an assumed event mean suspended solids concentration (typically 60 mg/L for urban sites). As a guideline, the U.S. EPA has determined typical annual sediment loads per acre for various sites by land use (see **Table 5**). Certain states and local jurisdictions have also established such guidelines.

For some sites the Jellyfish Filter is installed downstream of a detention facility. In these cases, the Jellyfish Filter will typically treat a relatively low flow rate (orifice-controlled release flow rate) from the detention facility compared to flow rates that would be treated if the Jellyfish Filter received the site runoff directly. In such cases, the size of the Jellyfish Filter and number of filter cartridges will typically be determined by the projected annual sediment mass load transported to the Jellyfish Filter, accounting for sediment mass that is expected to settle out in the upstream detention facility.

It is important for the engineer to confirm that the system design has adequate storage capacity for anticipated pollutant loads that will accumulate over the specified maintenance interval. The oil and sediment pollutant capacities for each standard Jellyfish Filter model are shown in **Table 2**.

Cartridge Length (in / mm)	Cartridge Dry Weight (lbs / kg)	Design Treatment Flow Rate <sup>1</sup> (gpm / Lps)	Design Sediment Mass Loading Capacity <sup>1, 2, 3</sup> (lbs / kg)
15 / 381	10 / 4.5	Draindown 11 / 0.7 Hi-Flo 22 / 1.4	Draindown 17 / 8 Hi-Flo 35 / 16
27 / 686	14.5 / 6.6	Draindown 20 / 1.3 Hi-Flo 40 / 2.5	Draindown 31 / 14 Hi-Flo 63 / 28
40 / 1016	19.5 / 8.9	Draindown 30 / 1.9 Hi-Flo 60 / 3.8	Draindown 46 / 21 Hi-Flo 93 / 42
54 / 1372	25 / 11.4	Draindown 40 / 2.5 Hi-Flo 80 / 5.0	Draindown 63 / 28 Hi-Flo 125 / 57

<sup>1</sup> Design flow rates and sediment mass loading capacities based on 18 inches (457 mm) of driving head

<sup>2</sup> Based on laboratory testing using simulated storm events and Sil-Co-Sil® 106 test sediment (d50 = 22 microns) at 40% of maximum cartridge flow rate.

<sup>3</sup> Sediment mass loading capacities expressed as pounds of NJPSD test sediment (1 – 1000 microns, d50 = 67 microns, characterized as 55% sand / 40% silt / 5% clay), using conversion factor of 1.66 from Sil-Co-Sil 106 to NJPSD

**Note:** Actual sediment mass loading capacity will vary depending on specific site characteristics



**Table 5**  
**Annual Total Suspended Solids Load by Land Use**  
**(lbs/acre/year)**  
**(kg/hectare/year)**

Commercial	Parking Lot	Residential Density			Highways	Industrials	Shopping Center
		High	Med.	Low			
1000	400	420	250	10	880	500	440
1124	450	472	281	11	989	562	494

**Source:** U.S. EPA Stormwater Best Management Practice Design Guide Volume 1, Appendix D, Table D-1, Burton and Pitt 2002

### 4.3 Continuous Simulation Sizing Tool

A software-based continuous simulation modeling tool such as **PCSWMM for Stormceptor®**, can be utilized to determine site hydrology from local historical rainfall data, thereby assist in sizing a Jellyfish Filter. In general, such a tool is useful in deriving the water quality treatment flow rate associated with treatment of a high percentage (typically 80 - 90%) of the average annual runoff volume. The appropriately sized Jellyfish Filter is then selected from **Table 1** based on the derived water quality treatment flow rate. Please contact Imbrium Systems for assistance with optional sizing methodology.

## Chapter 5

### 5.0 Jellyfish Filter Installation

The installation of the precast concrete or fiberglass Jellyfish Filter structure should conform to state highway, provincial or local specifications for the installation of maintenance manholes. Selected sections of a general specification that are applicable are summarized in the following sections.

For more information, please refer to the Jellyfish Filter Performance Specification with document title **Standard Specification – Water Quality Filter Treatment Device**.

#### Excavation

- Excavation and general site preparation for the installation of the Jellyfish Filter structure should conform to state highway, provincial or local specifications.
- Topsoil removed during the excavation should be stockpiled in designated areas and should not be mixed with subsoil or other materials.
- The Jellyfish Filter structure should not be installed on frozen ground.
- Excavation should extend a minimum of 12 inches (300 mm) from the precast concrete surfaces plus an allowance for shoring and bracing where required.
- If the bottom of the excavation provides an unsuitable foundation additional excavation may be required. In areas with a high water table, continuous dewatering may be required to ensure that the excavation is stable and free of water.



- Level the sub-grade to the proper elevation. Verify the elevation against the structure dimensions, the invert elevations on the approved Jellyfish Filter drawing and the site plans. Adjust the base aggregate if necessary. Verify the soil bearing capacity is adequate for the required load.

#### Installation of Jellyfish Filter Structure

- Set the base section of the Jellyfish Filter structure on solid sub-grade.
- Verify the level and elevation of the base section before adding any riser sections.
- Add specified watertight seal to the base section. Set riser section(s) on the base section.
- Install the inlet and outlet pipes to the structure.
- Install the top slab and frames and covers.
- Do not install Jellyfish membrane filtration cartridges until the upstream catchment and site have been stabilized.

#### Installation of Jellyfish Membrane Filtration Cartridges

- After the upstream catchment and site have been stabilized, remove any accumulated sediment and debris from the structure.
- Safely descend to the cartridge deck using the ladder attached to the sidewall of the manhole. Confined space entry procedures are required.
- Carefully lower the Jellyfish membrane filtration cartridges into the cartridge receptacles within the cartridge deck. A filter cartridge should be placed into each of the draindown cartridge receptacles outside the backwash pool weir. Depending on the specific Jellyfish Filter model number, filter cartridges should be placed into most or all of the hi-flo cartridge receptacles within the backwash pool weir. If a membrane joint snags on the receptacle lip, use a slight twisting or sideways motion to clear the snag. Do not force the membranes down into the cartridge receptacle, as this may damage the membranes. Use a slight downward pressure on the cartridge head plate to seat the rim gasket (thick circular gasket on the stainless steel head plate) into the cartridge receptacle.
- Examine the cartridge lids to differentiate lids with a small orifice, a large orifice and no orifice. Lids with a small orifice are to be inserted into the draindown cartridge receptacles. Lids with a large orifice are to be inserted into the hi-flo cartridge receptacles. Lids with no orifice are to be inserted into unoccupied cartridge receptacles within the backwash pool weir.
- To install a cartridge lid, ensure the cartridge lid male threads are aligned properly with the cartridge receptacle female threads. Firmly twist the cartridge lid clockwise to seat the filter cartridge snugly in place.

## Chapter 6

### 6.0 Jellyfish Filter Inspection and Maintenance

For inspection and maintenance information, please refer to the **Jellyfish® Filter Owner's Manual**.

Jellyfish Filter operation and maintenance information can be obtained from the **Jellyfish Filters Owner's Manual** on Imbrium Systems website ([www.imbriumsystems.com](http://www.imbriumsystems.com)).



---

## Chapter 7

### 7.0 Jellyfish Filter Replacement Parts

Replacement parts for the JellyfishFilter can be ordered by contacting Imbrium Systems at:

**United States:** 888-279-8826 or 301-279-8827

**Canada / International:** 800-565-4801 / 416-960-9900

[www.imbriumsystems.com](http://www.imbriumsystems.com)

## Chapter 8

### 8.0 Jellyfish Filter Performance Specification

The Jellyfish Filter Performance Specification is contained in the document titled **Standard Specification – Water Quality Filter Treatment Device**, shown in **Appendix B** and available on Imbrium Systems website.



Notes



# Appendix A

---

## Jellyfish® Filter Standard Drawings U.S. Customary Units



Notes





# Jellyfish<sup>®</sup> Filter Typical Layout

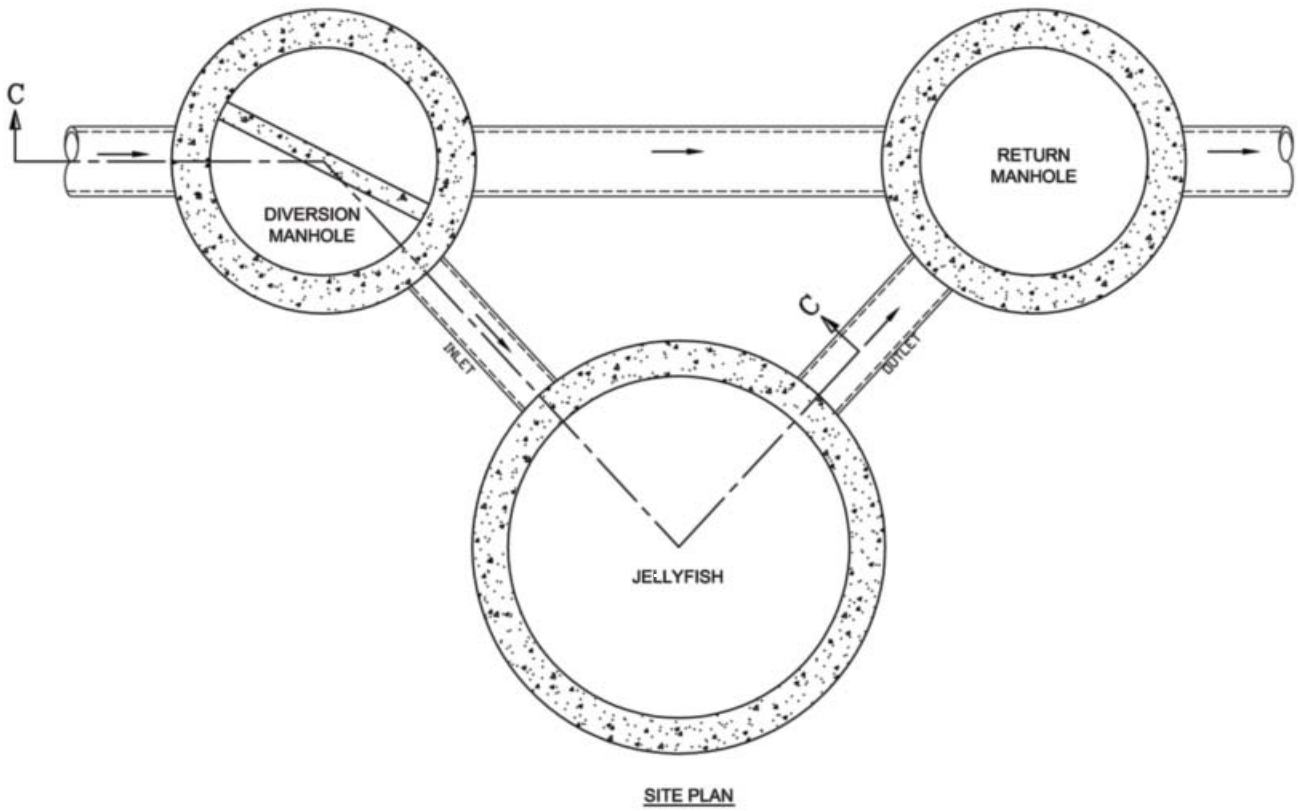

## Jellyfish® Filter JF4 Typical Section

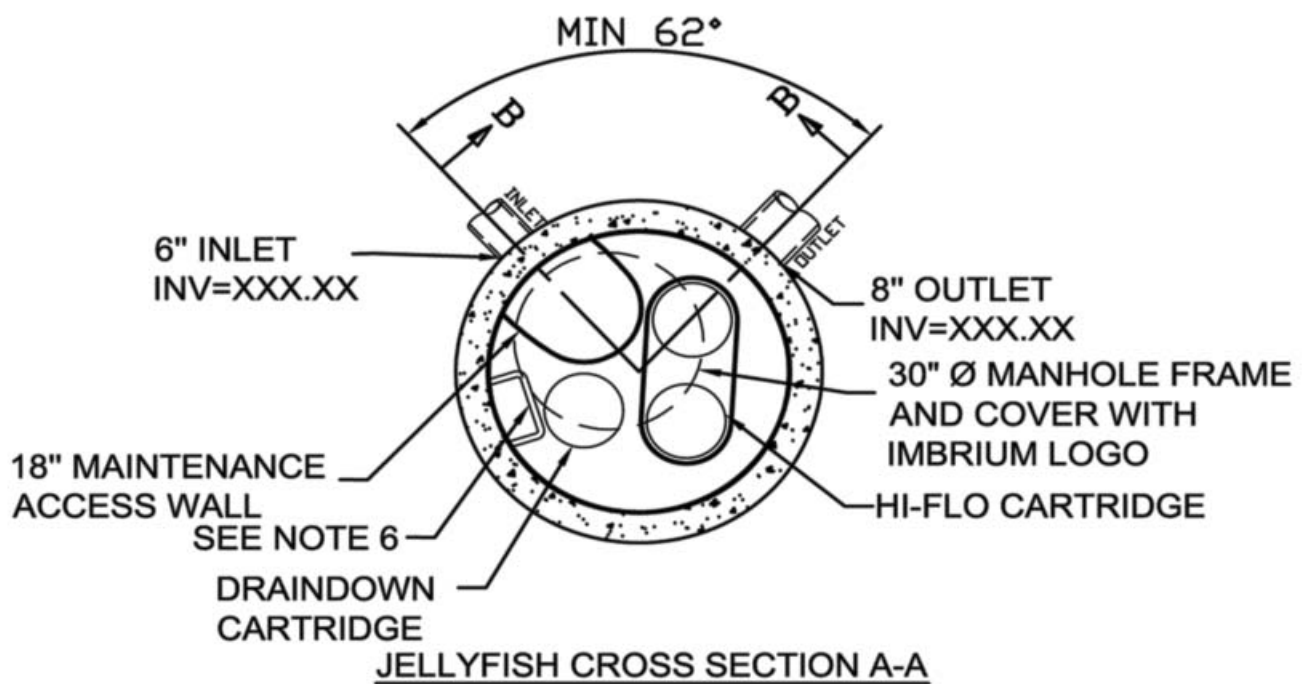

### Notes:

1. All sections and parts to meet or exceed ASTM C-478, ASTM C-443, and ASTM D-4097 corresponding to AASHTO specifications, and any other site or local standards.
2. Configuration of inlet and outlet can vary to meet site's needs.
3. Cartridge installation shall occur only after site has been stabilized and the Jellyfish unit is clean and free of debris. Cartridges shall be furnished new, at time of final acceptance.
4. The Jellyfish Membrane Filter is protected by the following patents: U.S. Patent No. 8,123,935; Other U.S. Patents Pending; International Patents Pending.
5. For site specific drawings please contact your local Imbrium Systems representative.



## Jellyfish<sup>®</sup> Filter JF4 Typical Section

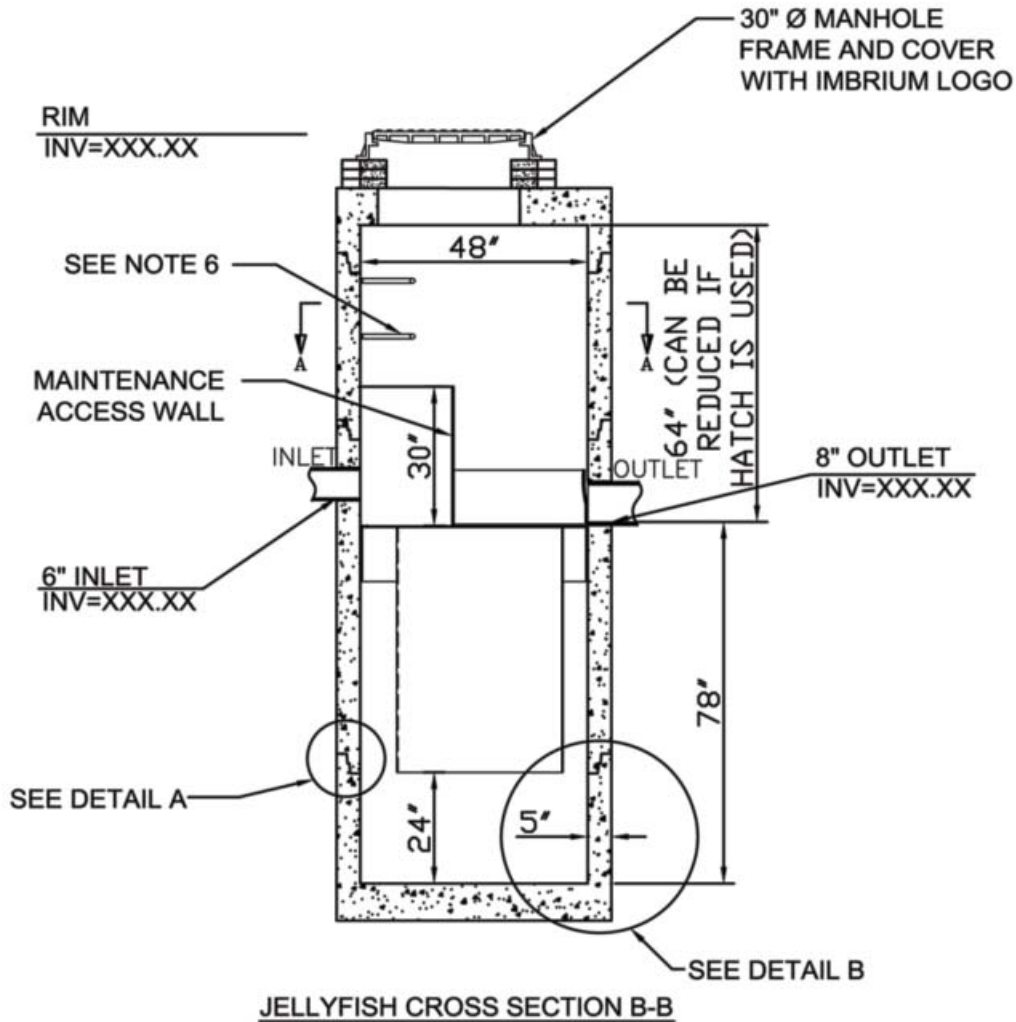

**Notes:**

1. All sections and parts to meet or exceed ASTM C-478, ASTM C-443, and ASTM D-4097 corresponding to AASHTO specifications, and any other site or local standards.
2. Configuration of inlet and outlet can vary to meet site's needs.
3. Cartridge installation shall occur only after site has been stabilized and the Jellyfish unit is clean and free of debris. Cartridges shall be furnished new, at time of final acceptance.
4. The Jellyfish Membrane Filter is protected by the following patents: U.S. Patent No. 8,123,935; Other U.S. Patents Pending; International Patents Pending.
5. For site specific drawings please contact your local Imbrium Systems representative.

## Jellyfish<sup>®</sup> Filter JF6 Typical Section

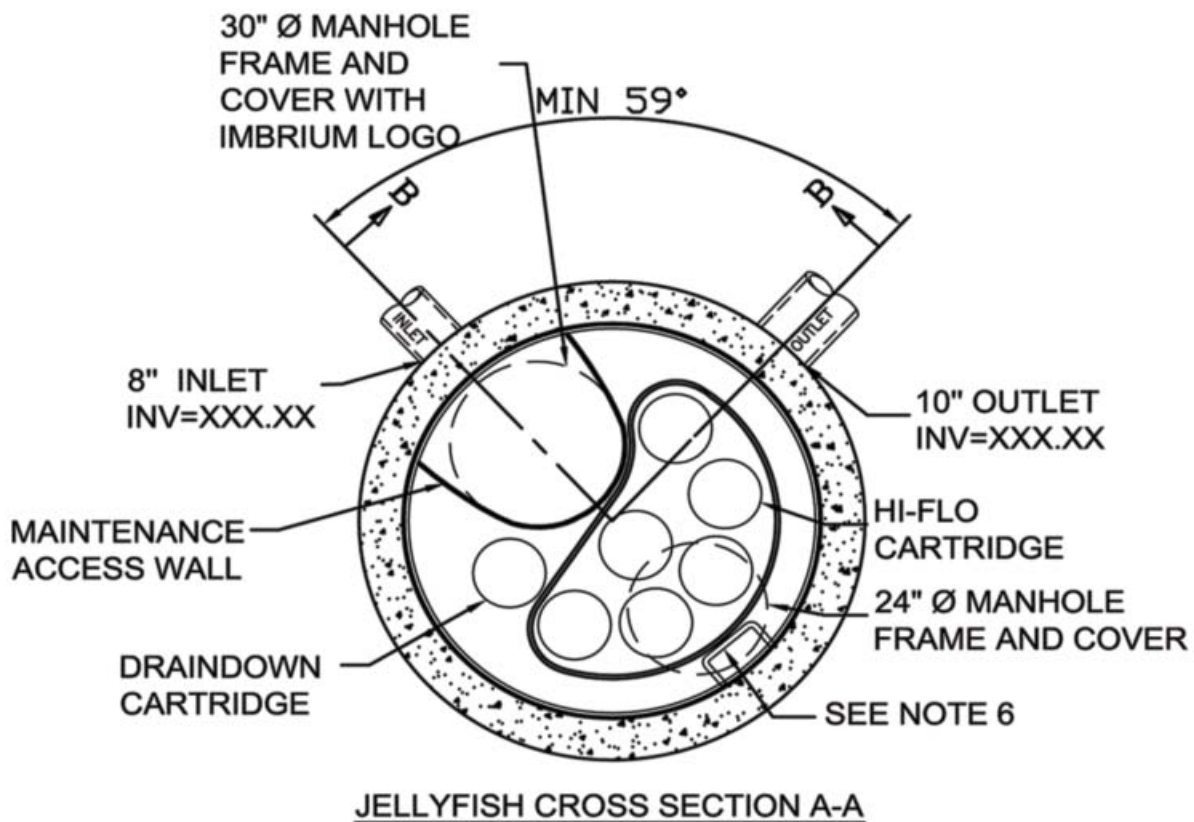

### Notes:

1. All sections and parts to meet or exceed ASTM C-478, ASTM C-443, and ASTM D-4097 corresponding to AASHTO specifications, and any other site or local standards.
2. Configuration of inlet and outlet can vary to meet site's needs.
3. Cartridge installation shall occur only after site has been stabilized and the Jellyfish unit is clean and free of debris. Cartridges shall be furnished new, at time of final acceptance.
4. The Jellyfish Membrane Filter is protected by the following patents: U.S. Patent No. 8,123,935; Other U.S. Patents Pending; International Patents Pending.
5. For site specific drawings please contact your local Imbrium Systems representative.



## Jellyfish<sup>®</sup> Filter JF6 Typical Section

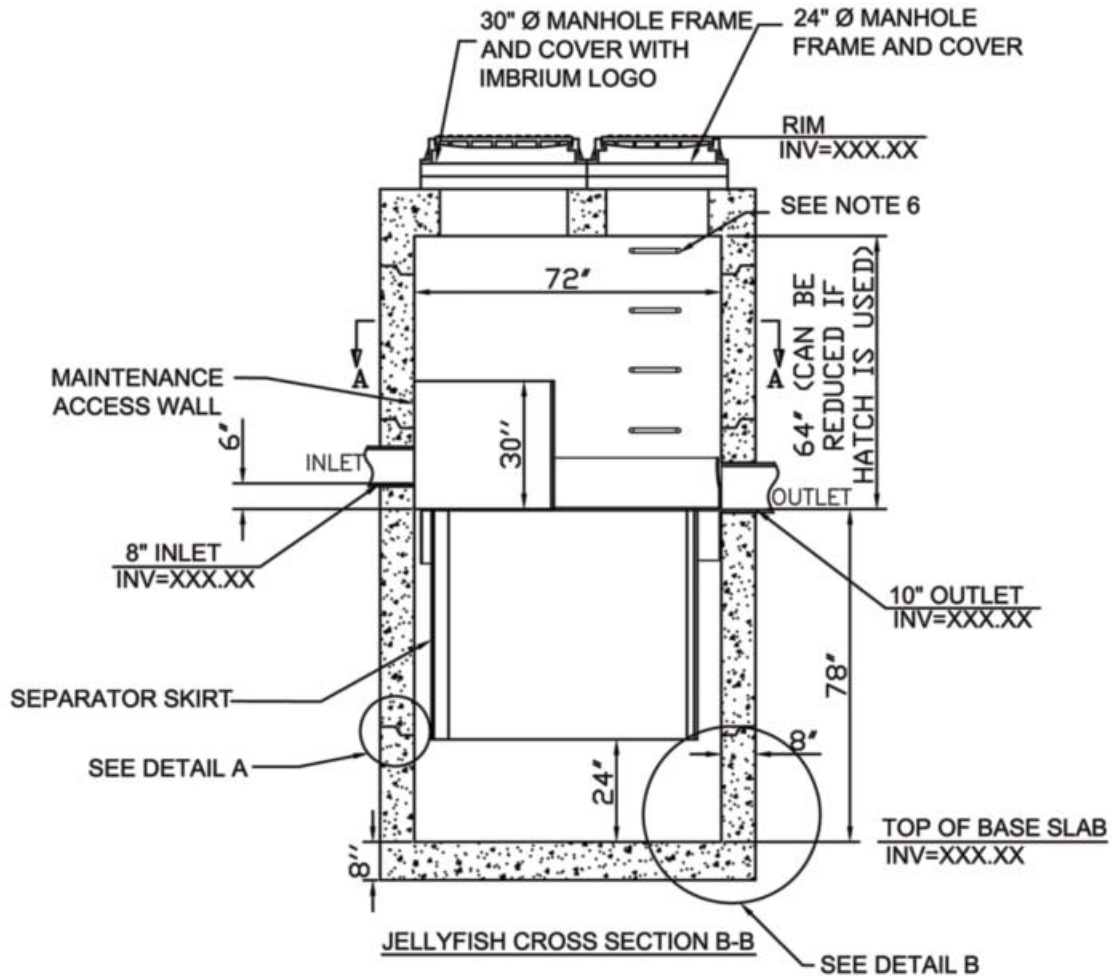

### Notes:

1. All sections and parts to meet or exceed ASTM C-478, ASTM C-443, and ASTM D-4097 corresponding to AASHTO specifications, and any other site or local standards.
2. Configuration of inlet and outlet can vary to meet site's needs.
3. Cartridge installation shall occur only after site has been stabilized and the Jellyfish unit is clean and free of debris. Cartridges shall be furnished new, at time of final acceptance.
4. The Jellyfish Membrane Filter is protected by the following patents: U.S. Patent No. 8,123,935; Other U.S. Patents Pending; International Patents Pending
5. For site specific drawings please contact your local Imbrium Systems representative.



## Jellyfish<sup>®</sup> Filter JF8 Typical Section

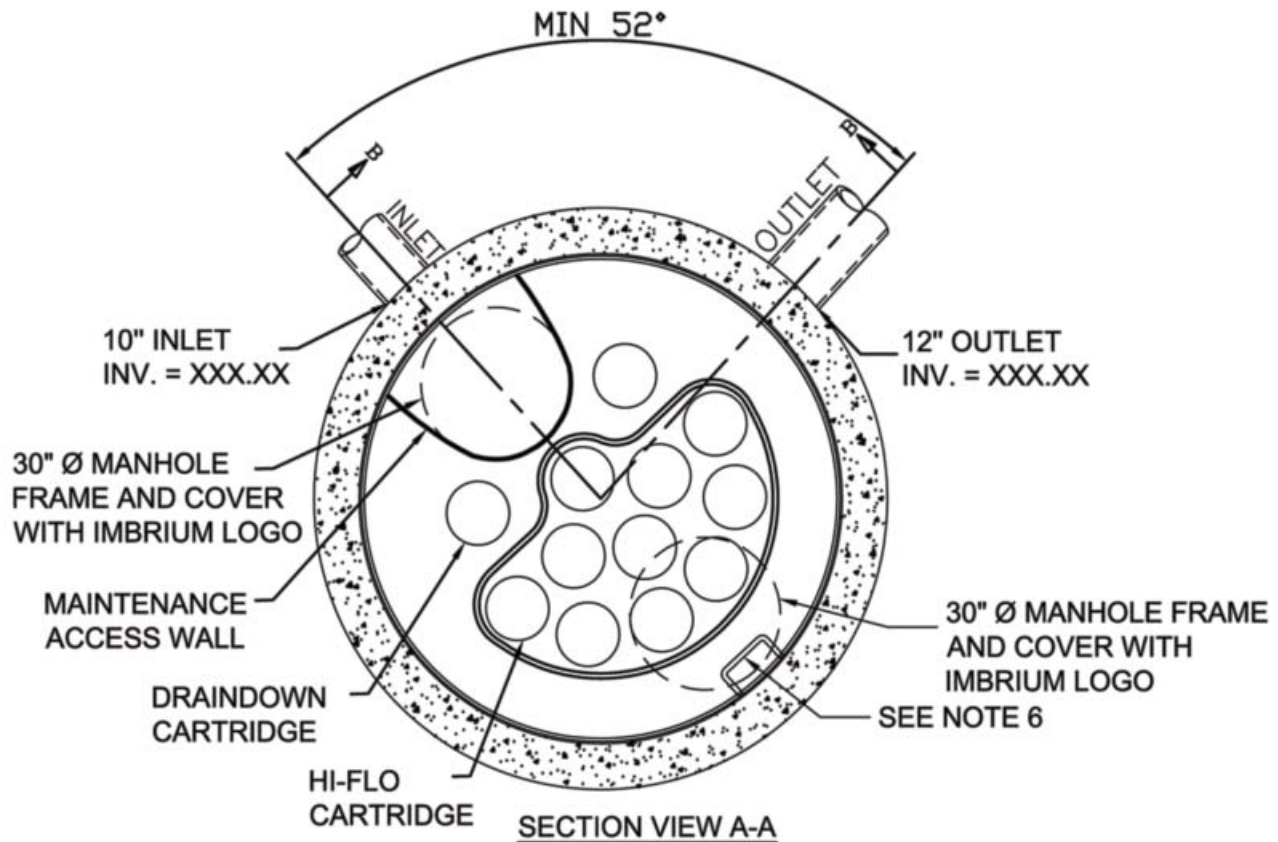

### Notes:

1. All sections and parts to meet or exceed ASTM C-478, ASTM C-443, and ASTM D-4097 corresponding to AASHTO specifications, and any other site or local standards.
2. Configuration of inlet and outlet can vary to meet site's needs.
3. Cartridge installation shall occur only after site has been stabilized and the Jellyfish unit is clean and free of debris. Cartridges shall be furnished new, at time of final acceptance.
4. The Jellyfish Membrane Filter is protected by the following patents: U.S. Patent No. 8,123,935; Other U.S. Patents Pending; International Patents Pending.
5. For site specific drawings please contact your local Imbrium Systems representative.



## Jellyfish<sup>®</sup> Filter JF8 Typical Section

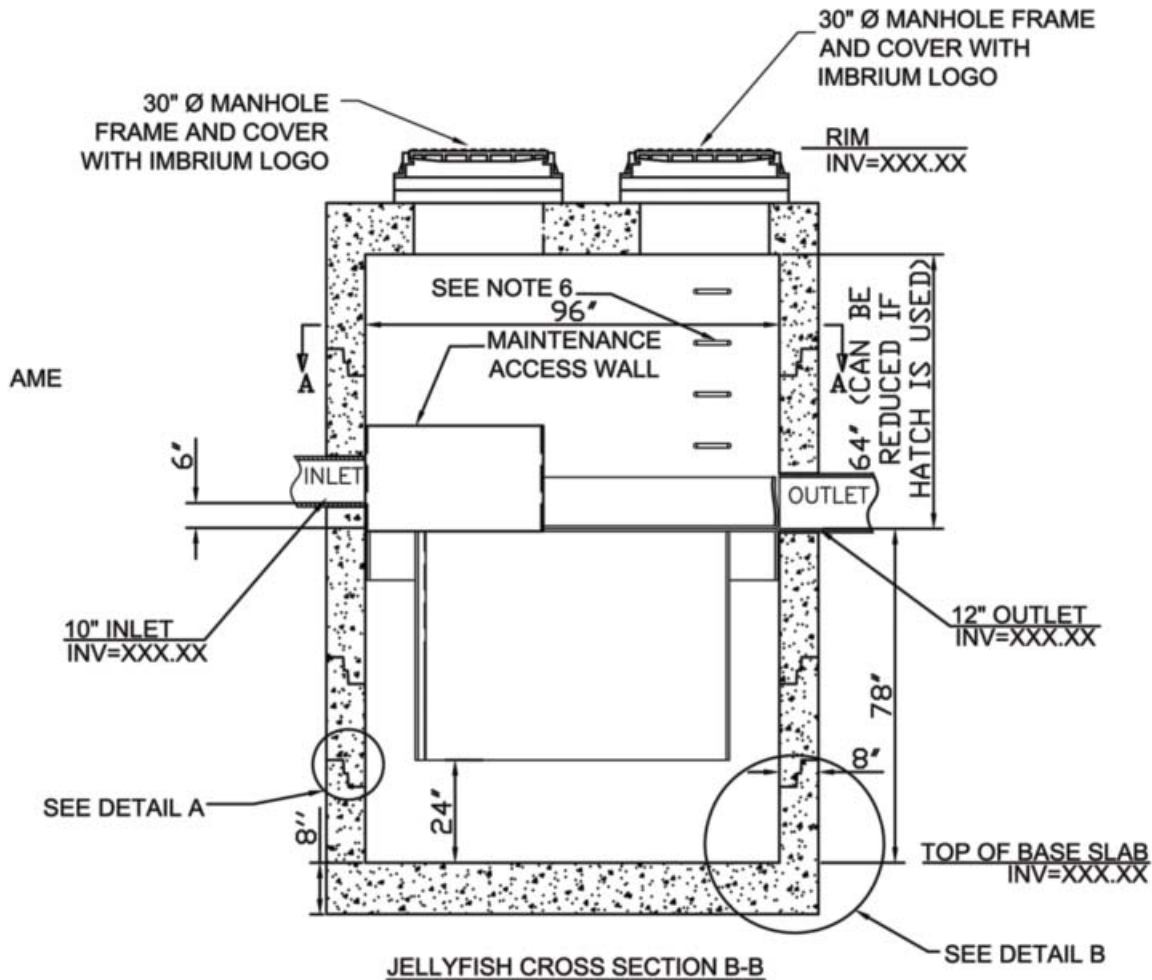

### Notes:

1. All sections and parts to meet or exceed ASTM C-478, ASTM C-443, and ASTM D-4097 corresponding to AASHTO specifications, and any other site or local standards.
2. Configuration of inlet and outlet can vary to meet site's needs.
3. Cartridge installation shall occur only after site has been stabilized and the Jellyfish unit is clean and free of debris. Cartridges shall be furnished new, at time of final acceptance.
4. The Jellyfish Membrane Filter is protected by the following patents: U.S. Patent No. 8,123,935; Other U.S. Patents Pending; International Patents Pending.
5. For site specific drawings please contact your local Imbrium Systems representative.



## Jellyfish<sup>®</sup> Filter JF10 Typical Section

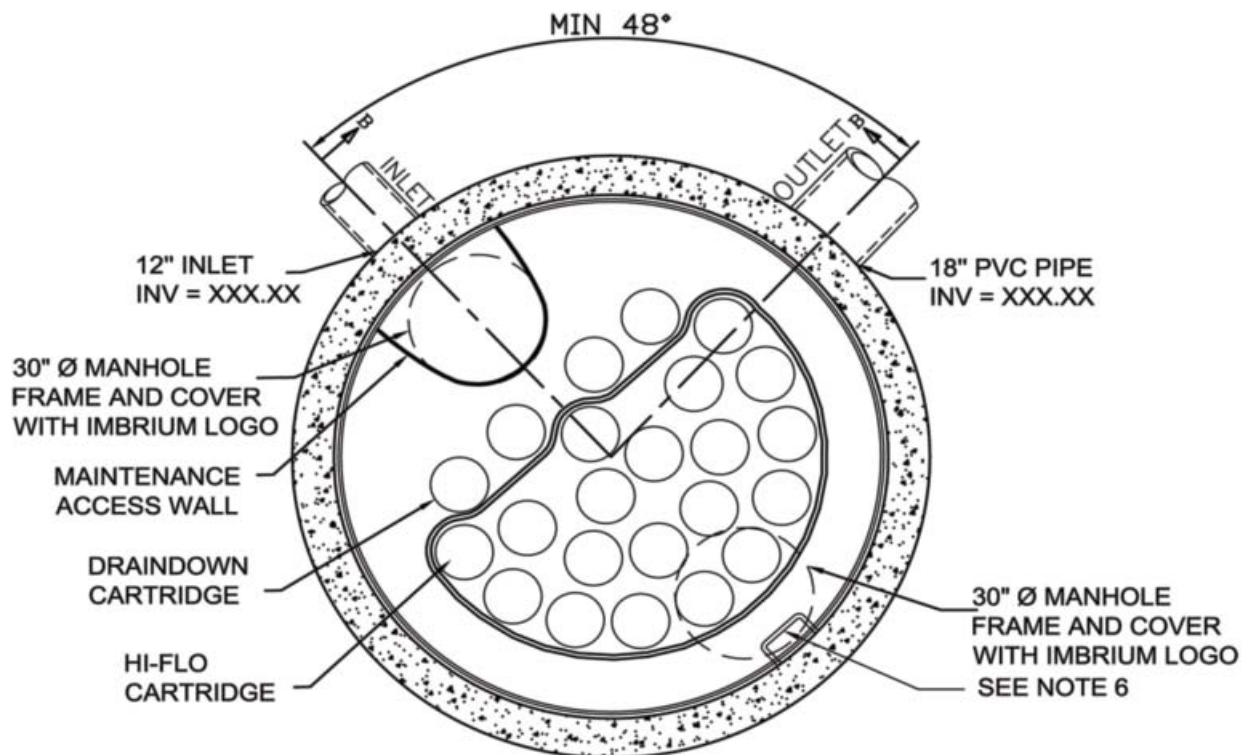

JELLYFISH CROSS SECTION A-A

### Notes:

1. All sections and parts to meet or exceed ASTM C-478, ASTM C-443, and ASTM D-4097 corresponding to AASHTO specifications, and any other site or local standards.
2. Configuration of inlet and outlet can vary to meet site's needs.
3. Cartridge installation shall occur only after site has been stabilized and the Jellyfish unit is clean and free of debris. Cartridges shall be furnished new, at time of final acceptance.
4. The Jellyfish Membrane Filter is protected by the following patents: U.S. Patent No. 8,123,935; Other U.S. Patents Pending; International Patents Pending.
5. For site specific drawings please contact your local Imbrium Systems representative.





## Jellyfish<sup>®</sup> Filter JF10 Typical Section

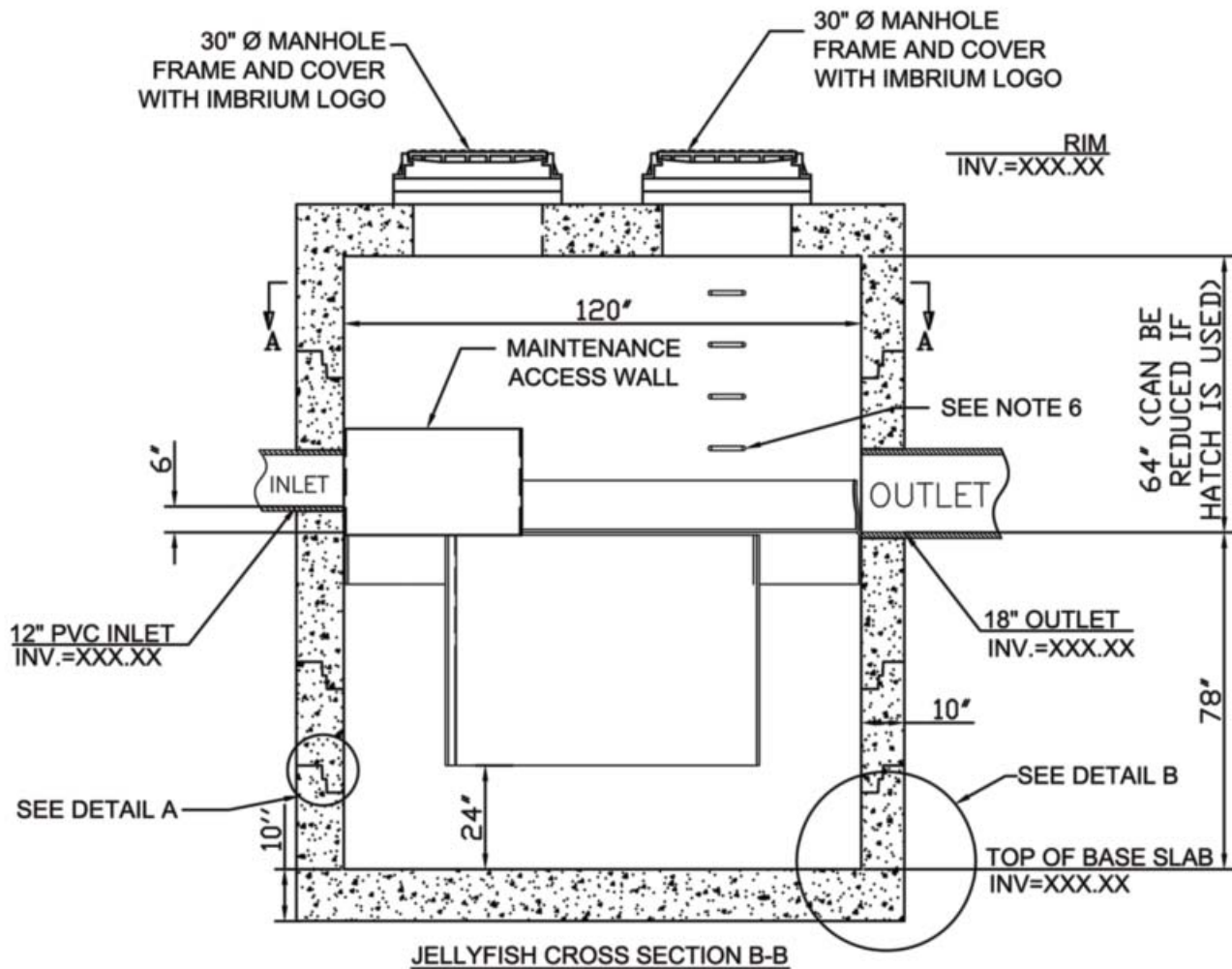

### Notes:

1. All sections and parts to meet or exceed ASTM C-478, ASTM C-443, and ASTM D-4097 corresponding to AASHTO specifications, and any other site or local standards.
2. Configuration of inlet and outlet can vary to meet site's needs.
3. Cartridge installation shall occur only after site has been stabilized and the Jellyfish unit is clean and free of debris. Cartridges shall be furnished new, at time of final acceptance.
4. The Jellyfish Membrane Filter is protected by the following patents: U.S. Patent No. 8,123,935; Other U.S. Patents Pending; International Patents Pending.
5. For site specific drawings please contact your local Imbrium Systems representative.



## Jellyfish<sup>®</sup> Filter JF12 Typical Section

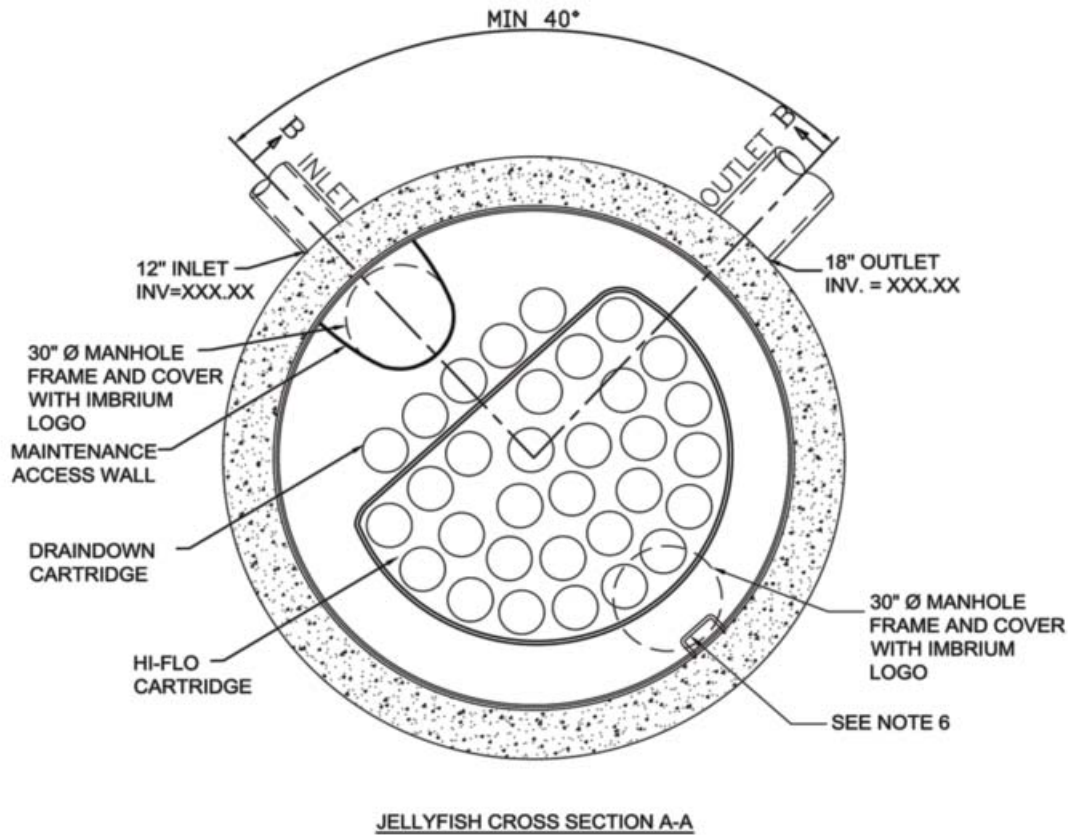

### Notes:

1. All sections and parts to meet or exceed ASTM C-478, ASTM C-443, and ASTM D-4097 corresponding to AASHTO specifications, and any other site or local standards.
2. Configuration of inlet and outlet can vary to meet site's needs.
3. Cartridge installation shall occur only after site has been stabilized and the Jellyfish unit is clean and free of debris. Cartridges shall be furnished new, at time of final acceptance.
4. The Jellyfish Membrane Filter is protected by the following patents: U.S. Patent No. 8,123,935; Other U.S. Patents Pending; International Patents Pending.
5. For site specific drawings please contact your local Imbrium Systems representative.



## Jellyfish<sup>®</sup> Filter JF12 Typical Section

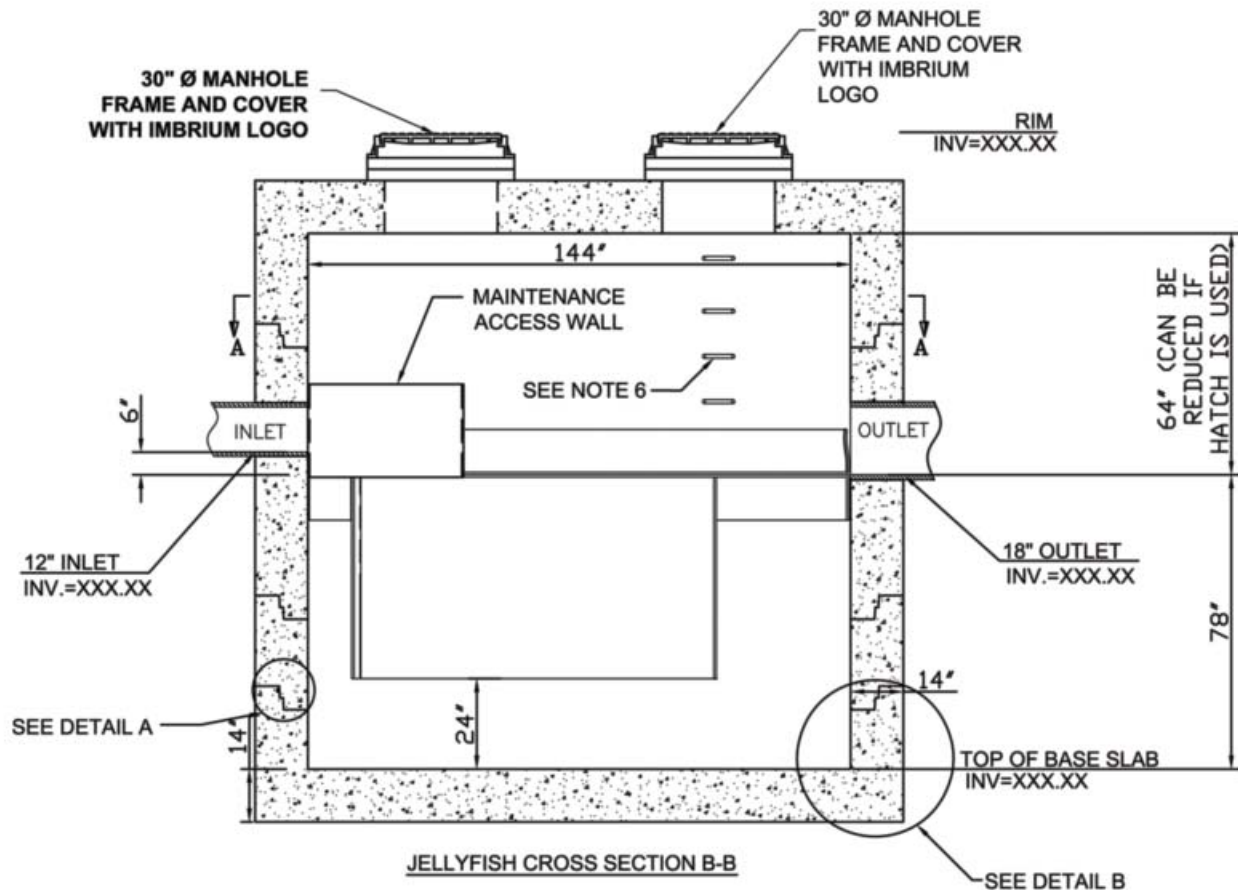

### Notes:

1. All sections and parts to meet or exceed ASTM C-478, ASTM C-443, and ASTM D-4097 corresponding to AASHTO specifications, and any other site or local standards.
2. Configuration of inlet and outlet can vary to meet site's needs.
3. Cartridge installation shall occur only after site has been stabilized and the Jellyfish unit is clean and free of debris. Cartridges shall be furnished new, at time of final acceptance.
4. The Jellyfish Membrane Filter is protected by the following patents: U.S. Patent No. 8,123,935; Other U.S. Patents Pending; International Patents Pending.
5. For site specific drawings please contact your local Imbrium Systems representative.



## Jellyfish<sup>®</sup> Filter for Shallow Application (with Hatch) Typical Section

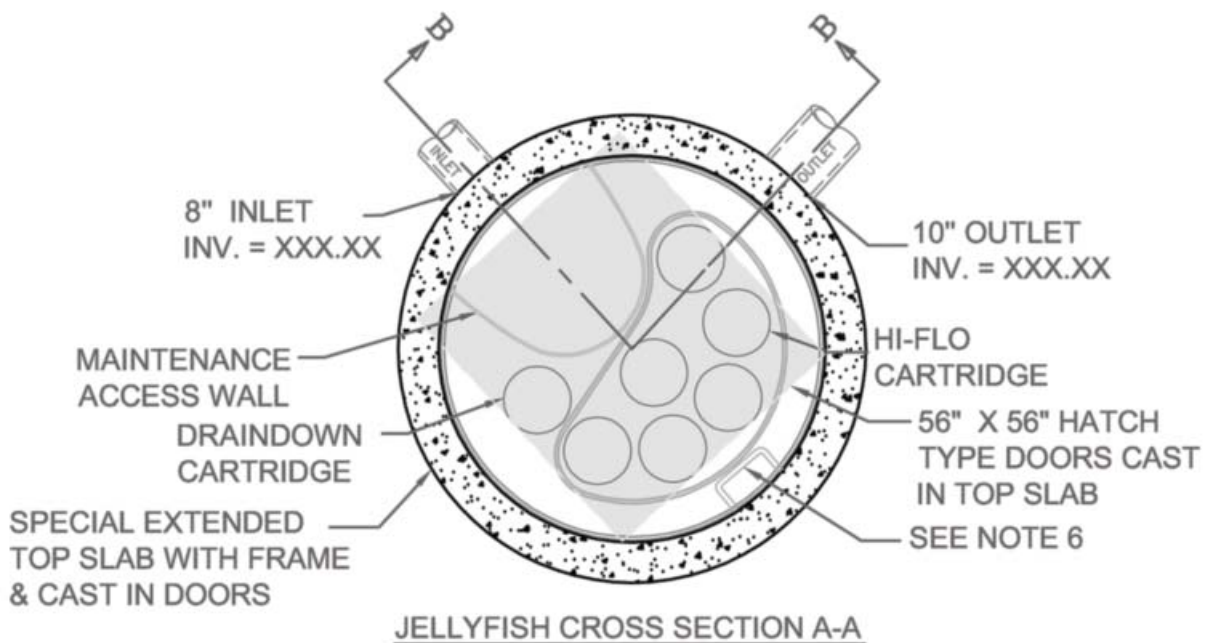

### Notes:

1. All sections and parts to meet or exceed ASTM C-478, ASTM C-443, and ASTM D-4097 corresponding to AASHTO specifications, and any other site or local standards.
2. Configuration of inlet and outlet can vary to meet site's needs.
3. Cartridge installation shall occur only after site has been stabilized and the Jellyfish unit is clean and free of debris. Cartridges shall be furnished new, at time of final acceptance.
4. The Jellyfish Membrane Filter is protected by the following patents: Patents Pending.
5. For site specific drawings please contact your local Imbrium Systems representative.



## Jellyfish<sup>®</sup> Filter for Shallow Application (with Hatch) Typical Section

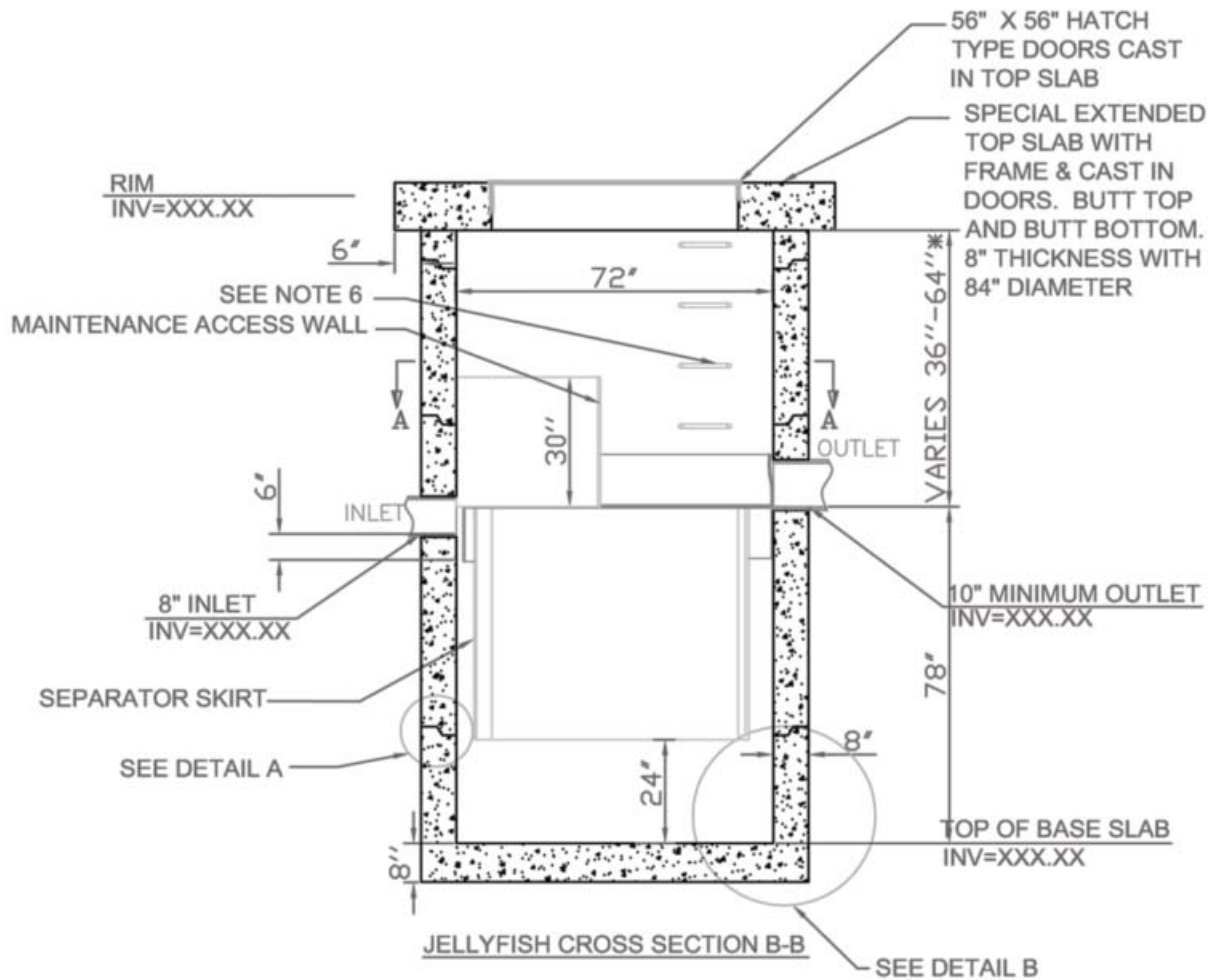

**Notes:**

1. All sections and parts to meet or exceed ASTM C-478, ASTM C-443, and ASTM D-4097 corresponding to AASHTO specifications, and any other site or local standards.
2. Configuration of inlet and outlet can vary to meet site's needs.
3. Cartridge installation shall occur only after site has been stabilized and the Jellyfish unit is clean and free of debris. Cartridges shall be furnished new, at time of final acceptance.
4. The Jellyfish Membrane Filter is protected by the following patents: Patents Pending.
5. For site specific drawings please contact your local Imbrium Systems representative.

# Offline Jellyfish® Filter with Grated Inlet Typical Drawing

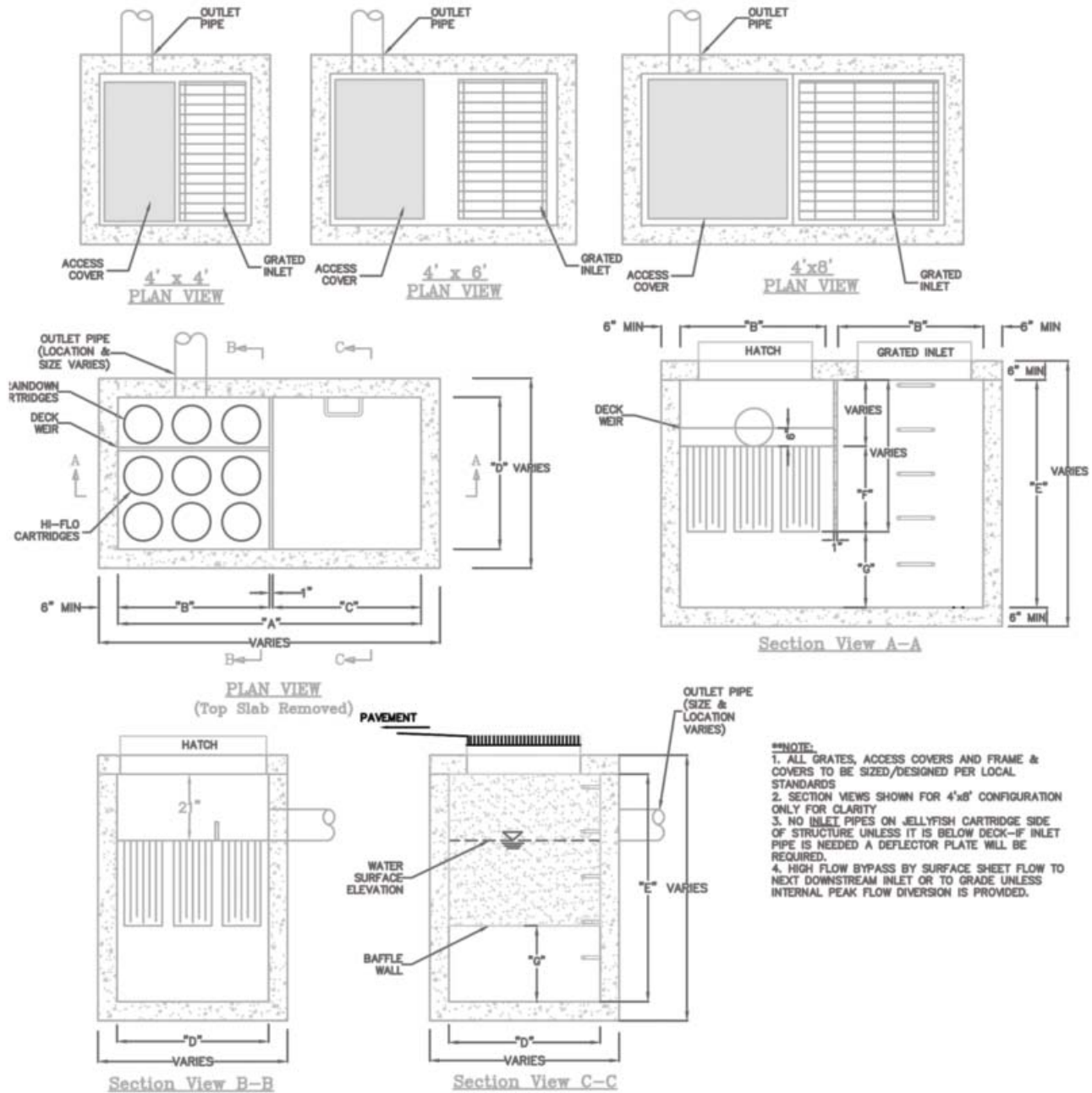

## Jellyfish Filter Grated Inlet Table

Structure	Cover Dim (Ped or H-20)	Grate Size	"A" I.D. Length	"B" Deck Width	"C" Inlet Chamber Width	"D" I.D. Width	"E" Min I.D. Height	"F" Cartridge Length	"G" Sump
4' x 4'	28" x 44"	24" Dia.	48"	17.5"	48"	48"	48"	15"	18"
4' x 4'	28" x 44"	24" Dia.	48"	17.5"	48"	48"	72"	27"	24"
4' x 4'	28" x 44"	24" Dia.	48"	17.5"	48"	48"	118"	40"	24"

Structure	Cover Dim (Ped or H-20)	Grate Size	"A" I.D. Length	"B" Deck Width	"C" Inlet Chamber Width	"D" I.D. Width	"E" Min I.D. Height	"F" Cartridge Length	"G" Sump
4' x 6'	28" x 44"	28" x 44"	72"	33.5"	38"	48"	48"	15"	18"
4' x 6'	28" x 44"	28" x 44"	72"	33.5"	38"	48"	72"	27"	24"
4' x 6'	28" x 44"	28" x 44"	72"	33.5"	38"	48"	118"	40"	24"

Structure	Cover Dim (Ped or H-20)	Grate Size	"A" I.D. Length	"B" Deck Width	"C" Inlet Chamber Width	"D" I.D. Width	"E" Min I.D. Height	"F" Cartridge Length	"G" Sump
4' x 8'	44" x 44"	44" x 44"	96"	47.5"	48"	48"	48"	15"	18"
4' x 8'	44" x 44"	44" x 44"	96"	47.5"	48"	48"	72"	27"	24"
4' x 8'	44" x 44"	44" x 44"	96"	47.5"	48"	48"	118"	40"	24"

Structure and Model No.	"F" Cartridge Length	Cartridge Type	Design Flow Rate Per Cartridge (gpm)	Max. No of Cartridges	Design Treatment Flow Rate with Max No. of Cartridges (gpm / cfs)
4' x 4' JFG4-2-1	15"	Draindown Hi-Flo	11	1	55 / 0.12
			22	2	
4' x 4' JFG4-2-1	27"	Draindown Hi-Flo	20	1	100 / 0.22
			40	2	
4' x 4' JFG4-2-1	40"	Draindown Hi-Flo	30	1	150 / 0.33
			60	2	
4' x 6' JFG6-4-2	15"	Draindown Hi-Flo	11	2	110 / 0.25
			22	4	
4' x 6' JFG6-4-2	27"	Draindown Hi-Flo	20	2	200 / 0.45
			40	4	
4' x 6' JFG6-6-3	40"	Draindown Hi-Flo	30	2	300 / 0.67
			60	4	
4' x 8' JFG8-6-3	15"	Draindown Hi-Flo	11	3	165 / 0.37
			22	6	
4' x 8' JFG8-6-3	27"	Draindown Hi-Flo	20	3	300 / 0.67
			40	6	
4' x 8' JFG8-6-3	40"	Draindown Hi-Flo	30	3	450 / 1.00
			60	6	

# Offline Jellyfish® Filter with Curb Inlet Typical Drawing

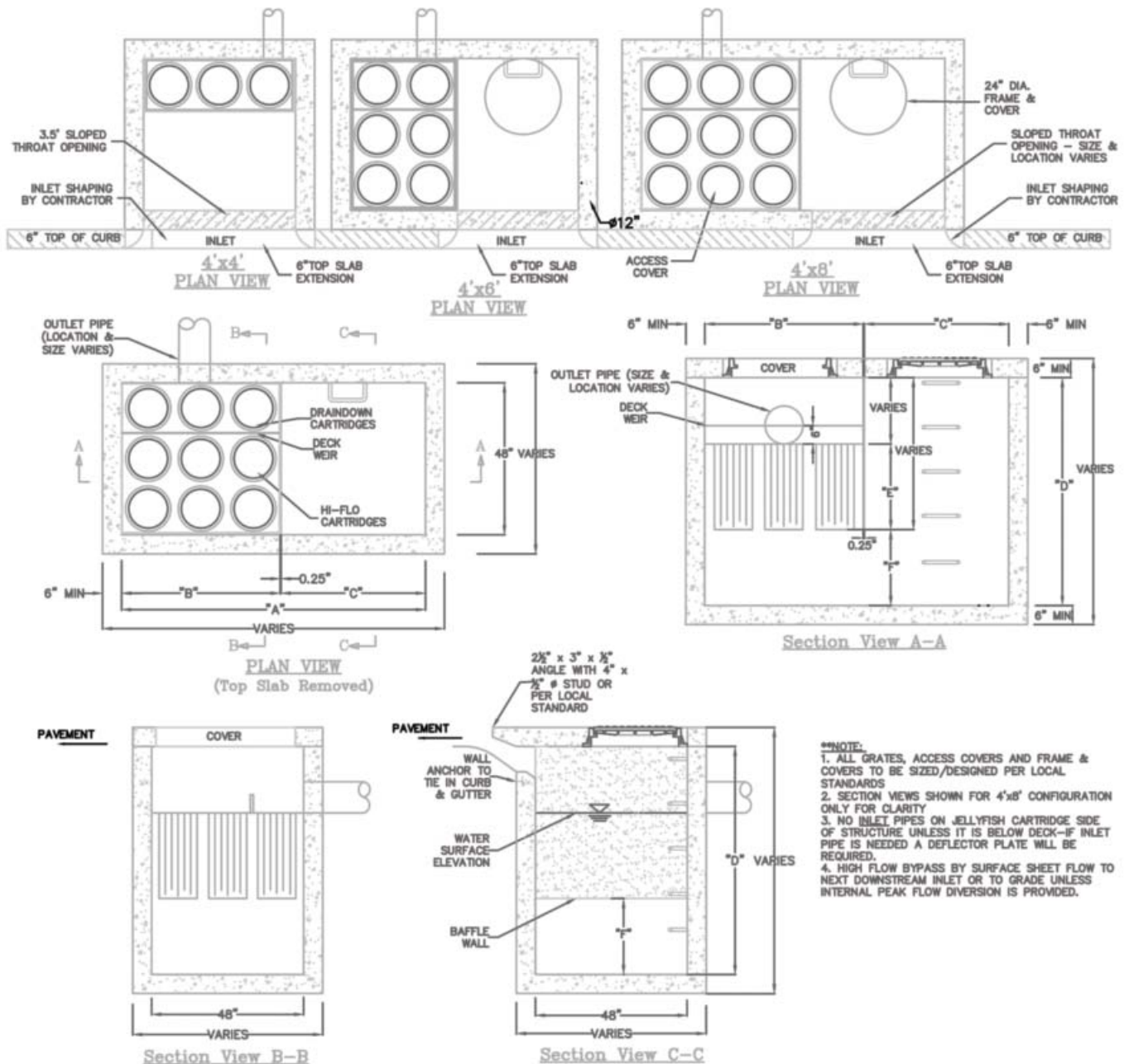



## Jellyfish Filter Curb Inlet Table

Structure	Cover Dim (Ped Rated)	"A" I.D. Length	"B" Deck Length	"C" Inlet Chamber Length	"D" Min I.D. Height	"E" Cartridge Length	"F" Sump
4' x 4'	30" x 48"	48"	47.5"	48"	48"	15"	18"
4' x 4'	30" x 48"	48"	47.5"	48"	72"	27"	24"
4' x 4'	30" x 48"	48"	47.5"	48"	118"	40"	24"

Structure	Cover Dim (Ped Rated)	Frame and Cover	"A" I.D. Length	"B" Deck Length	"C" Inlet Chamber Length	"D" Min I.D. Height	"E" Cartridge Length	"F" Sump
4' x 6'	30" x 48"	24" Dia.	72"	33.5"	38.25"	48"	15"	18"
4' x 6'	30" x 48"	24" Dia.	72"	33.5"	38.25"	72"	27"	24"
4' x 6'	30" x 48"	24" Dia.	72"	33.5"	38.25"	118"	40"	24"

Structure	Cover Dim (Ped Rated)	Frame and Cover	"A" I.D. Length	"B" Deck Length	"C" Inlet Chamber Length	"D" Min I.D. Height	"E" Cartridge Length	"F" Sump
4' x 8'	44" x 44"	24" Dia.	96"	47.5"	48.25"	48"	15"	18"
4' x 8'	44" x 44"	24" Dia.	96"	47.5"	48.25"	72"	27"	24"
4' x 8'	44" x 44"	24" Dia.	96"	47.5"	48.25"	118"	40"	24"

Structure and Model No.	"F" Cartridge Length	Cartridge Type	Design Flow Rate Per Cartridge (gpm)	Max. No of Cartridges	Design Treatment Flow Rate with Max No. of Cartridges (gpm / cfs)
4' x 4' JFC4-2-1	15"	Draindown	11	1	55 / 0.12
		Hi-Flo	22	2	
4' x 4' JFC4-2-1	27"	Draindown	20	1	100 / 0.22
		Hi-Flo	40	2	
4' x 4' JFC4-2-1	40"	Draindown	30	1	150 / 0.33
		Hi-Flo	60	2	
4' x 6' JFC6-4-2	15"	Draindown	11	2	110 / 0.25
		Hi-Flo	22	4	
4' x 6' JFC6-4-2	27"	Draindown	20	2	200 / 0.45
		Hi-Flo	40	4	
4' x 6' JFC6-6-3	40"	Draindown	30	2	300 / 0.67
		Hi-Flo	60	4	
4' x 8' JFC8-6-3	15"	Draindown	11	3	165 / 0.37
		Hi-Flo	22	6	
4' x 8' JFC8-6-3	27"	Draindown	20	3	300 / 0.67
		Hi-Flo	40	6	
4' x 8' JFC8-6-3	40"	Draindown	30	3	450 / 1.00
		Hi-Flo	60	6	

## Online Jellyfish® Filter with Curb or Grated Inlet Showing Optional Hood

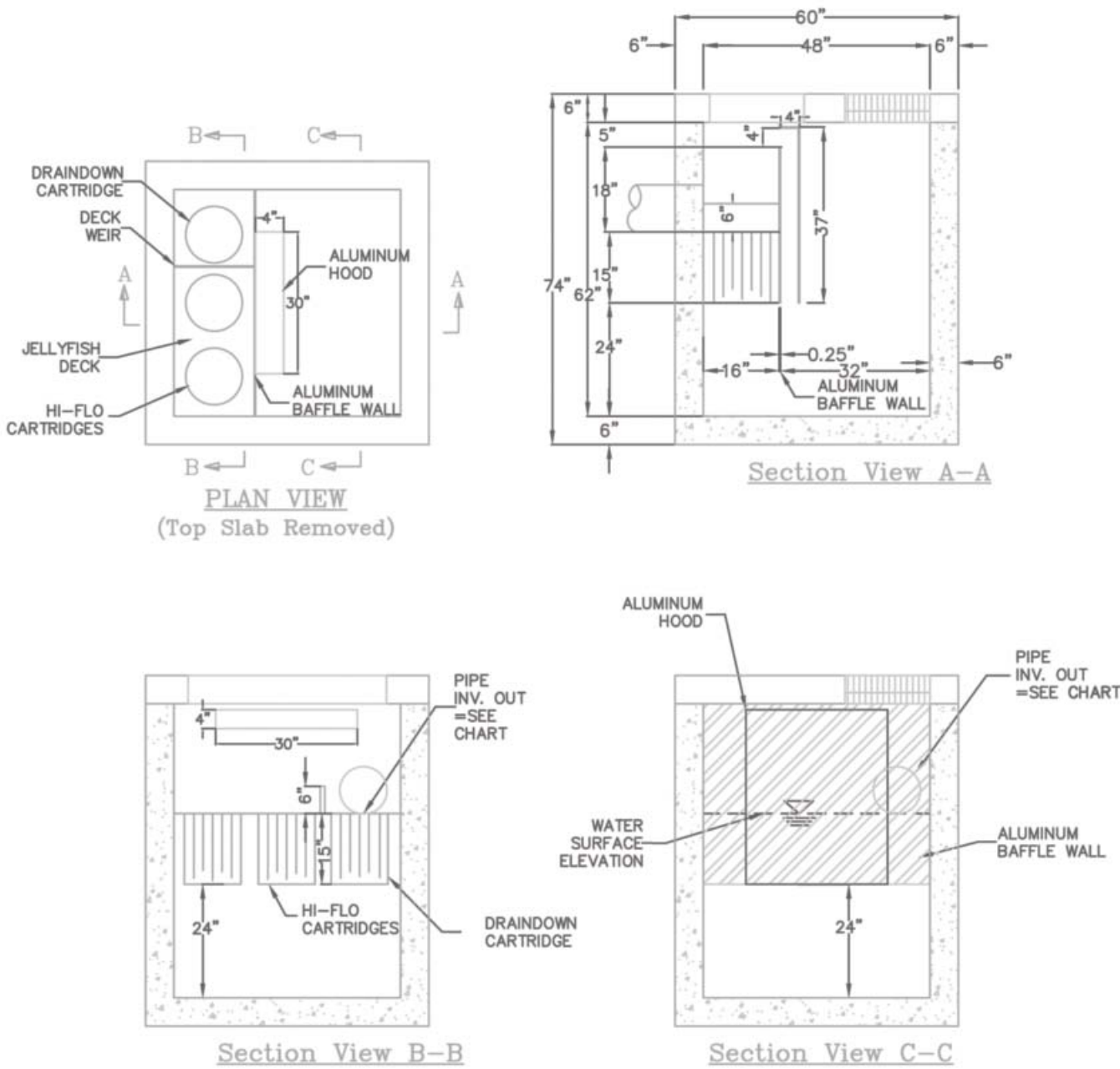

## Jellyfish<sup>®</sup> Filter with Sump Drain Typical Section

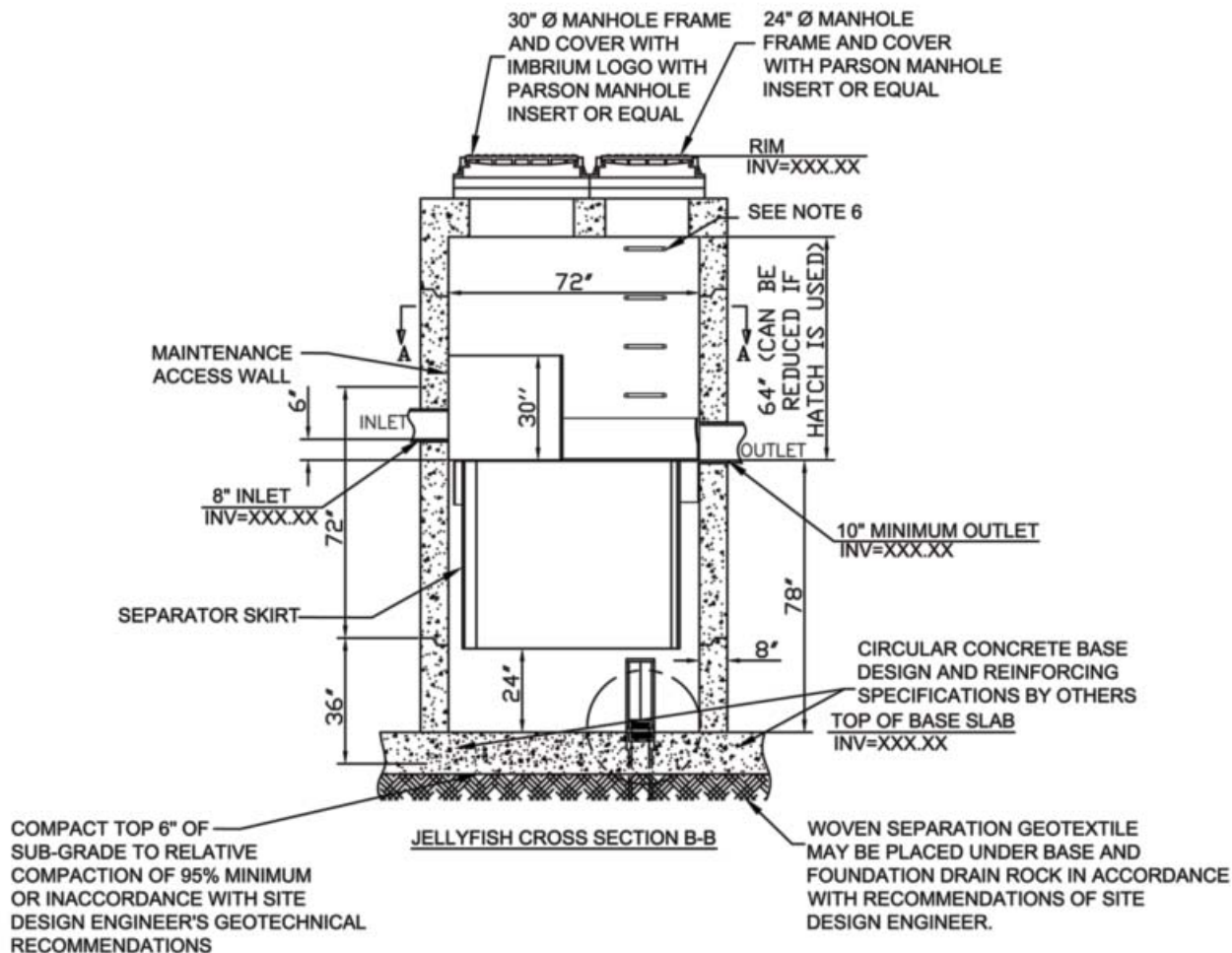

### Notes:

1. All sections and parts to meet or exceed ASTM C-478, ASTM C-443, and ASTM D-4097 corresponding to AASHTO specifications, and any other site or local standards.
2. Configuration of inlet and outlet can vary to meet site's needs.
3. Cartridge installation shall occur only after site has been stabilized and the Jellyfish unit is clean and free of debris. Cartridges shall be furnished new, at time of final acceptance.
4. The Jellyfish Membrane Filter is protected by the following patents: U.S. Patent No. 8,123,935; Other U.S. Patents Pending; International Patents Pending.
5. For site specific drawings please contact your local Imbrium Systems representative.



## FRP (Fiberglass) Jellyfish<sup>®</sup> Filter Typical Section

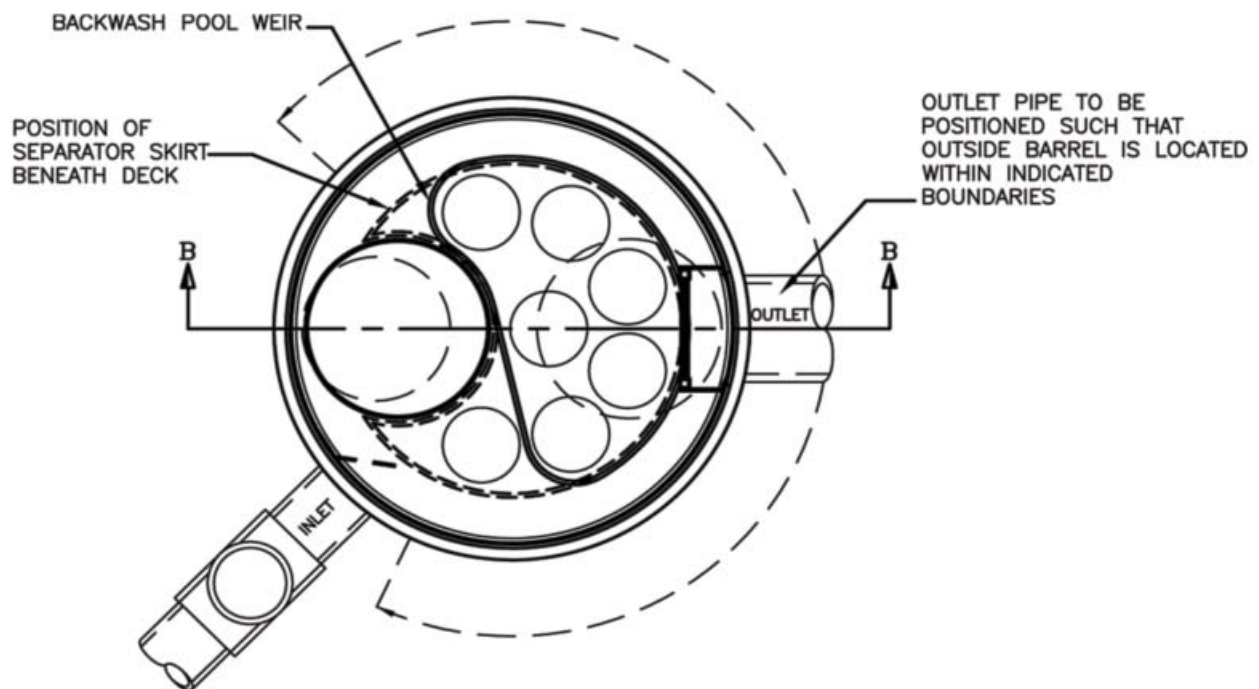

### Notes:

1. All sections and parts to meet or exceed ASTM C-478, ASTM C-443, and ASTM D-4097 corresponding to AASHTO specifications, and any other site or local standards.
2. Configuration of inlet and outlet can vary to meet site's needs.
3. Cartridge installation shall occur only after site has been stabilized and the Jellyfish unit is clean and free of debris. Cartridges shall be furnished new, at time of final acceptance.
4. The Jellyfish Membrane Filter is protected by the following patents: U.S. Patent No. 8,123,935; Other U.S. Patents Pending; International Patents Pending.
5. For site specific drawings please contact your local Imbrium Systems representative.

## FRP (Fiberglass) Jellyfish® Filter Typical Section

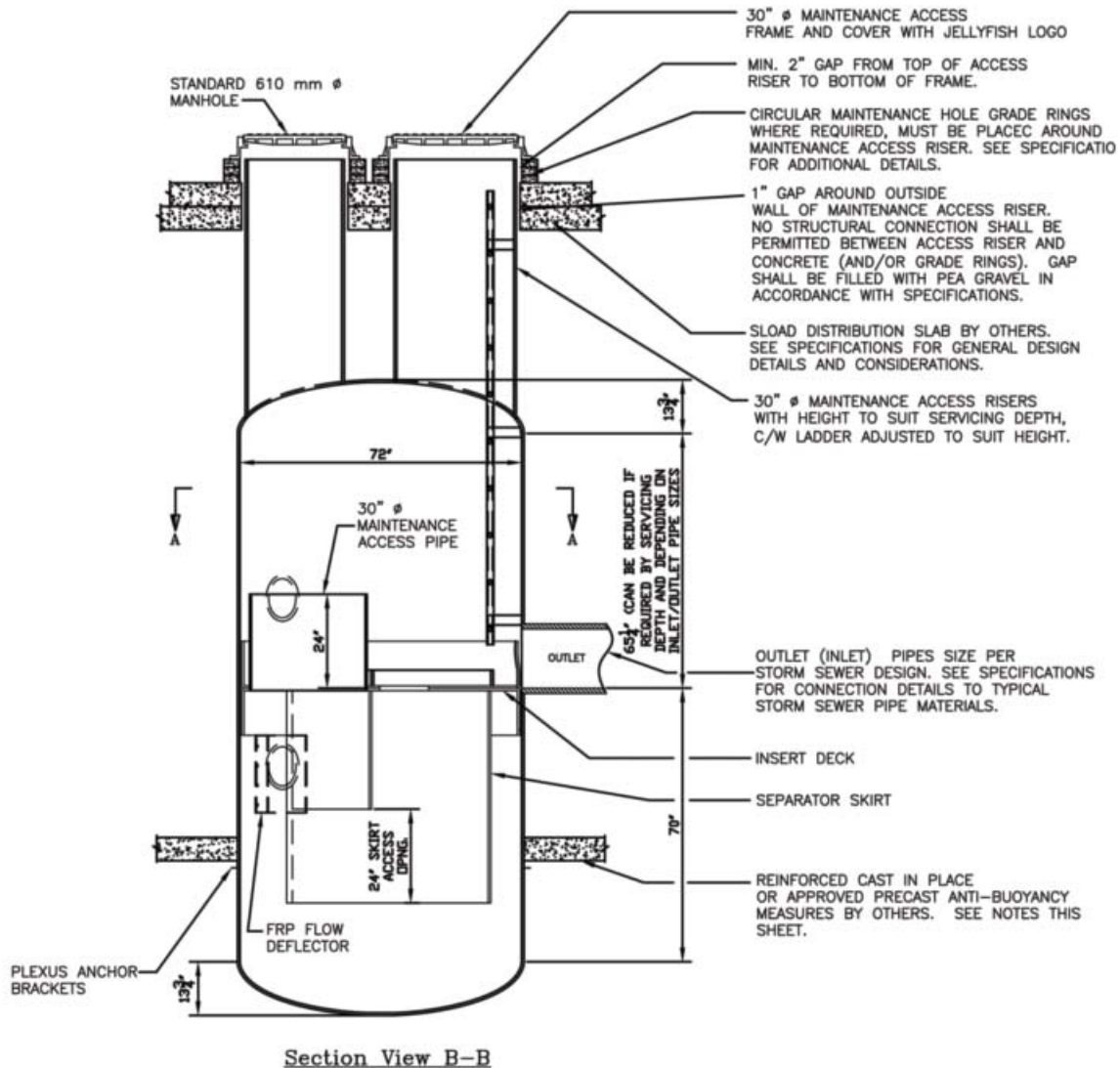

### Notes:

1. All sections and parts to meet or exceed ASTM C-478, ASTM C-443, and ASTM D-4097 corresponding to AASHTO specifications, and any other site or local standards.
2. Configuration of inlet and outlet can vary to meet site's needs.
3. Cartridge installation shall occur only after site has been stabilized and the Jellyfish unit is clean and free of debris. Cartridges shall be furnished new, at time of final acceptance.
4. The Jellyfish Membrane Filter is protected by the following patents: U.S. Patent No. 8,123,935; Other U.S. Patents Pending; International Patents Pending.
5. For site specific drawings please contact your local Imbrium Systems representative.

Notes



# Appendix B

---

## **Jellyfish® Filter Standard Specifications Water Quality Filter Treatment Device**



Notes





## Part 1- General

### 1.1 Work Included

Specifies requirements for construction and performance of an underground stormwater quality filter treatment device that removes pollutants from stormwater runoff through the unit operations of sedimentation, floatation and membrane filtration.

### 1.2 Reference Standards

- ASTM C 891: Specification for Installation of Underground Precast Concrete Utility Structures
- ASTM D 4097: Contact Molded Glass Fiber Reinforced Chemical Resistant Tanks
- ASTM C 478: Specification for Precast Reinforced Concrete Manhole Sections
- ASTM C 443: Specification for Joints for Concrete Pipe and Manholes, Using Rubber Gaskets
- ASTM D 4101: Specification for Copolymer steps construction

### 1.3 Shop Drawings

Shop drawings for the structure and performance are to be submitted with each order to the contractor. Contractor shall forward shop drawing submittal to the consulting engineer for approval. Shop drawings are to detail the structure precast concrete and/or fiberglass (FRP) components.

### 1.4 Handling and Storage

Prevent damage to materials during storage and handling.

## Part 2 - Products

### 2.1 General

#### 2.1.1

The device shall be circular or rectangular and constructed from precast concrete riser and slab components or monolithic precast structure(s), installed to conform to ASTM C 891 and to any required state highway, municipal or local specifications. Alternatively, the device shall be constructed of fiberglass (FRP), installed to conform to applicable sections of state, provincial and municipal building codes, highway, municipal or local specifications for the construction of such devices.

#### 2.1.2 Fiberglass Insert (Cartridge Deck)

The concrete device shall include a fiberglass insert bolted and sealed watertight inside the precast concrete chamber. Alternatively, the fiberglass device shall include a fiberglass insert bolted and/or chemically welded watertight inside the fiberglass chamber. The fiberglass insert shall serve as: (a) a horizontal divider between the lower treatment zone and the upper treated effluent zone; (b) a deck for attachment of filter cartridges such that the membrane filter elements of each cartridge extend into the lower treatment zone; (c) a platform for maintenance workers to service the filter cartridges; (d) a conduit for conveyance of treated water to the effluent pipe.



### 2.1.3 Membrane Filter Cartridges

Filter cartridges shall be comprised of cylindrical membrane filter elements connected to a perforated head plate. The number of membrane filter elements per cartridge shall be eleven 2.75-inch (70-mm) diameter elements. The length of each filter element shall be a minimum 27 inches (690 mm). Each cartridge shall be fitted into the cartridge deck by insertion into a cartridge receptacle that is permanently mounted into the cartridge deck. Each cartridge shall be secured by a cartridge lid that is threaded onto the receptacle. The maximum treatment flow rate of a filter cartridge shall be controlled by an orifice in the cartridge lid and based on a design flux rate determined by the maximum treatment flow rate per unit of filtration membrane surface area. The maximum flux rate shall be 0.21 gpm/ft<sup>2</sup> (0.142 lps/m<sup>2</sup>).

Each lightweight membrane filter cartridge shall allow for manual installation and removal and shall have a dry installation weight not to exceed the following:

<b>Cartridge Length (in / mm)</b>	<b>Cartridge Dry Weight (lbs / kg)</b>
15 / 381	10 / 4.5
27 / 686	14.5 / 6.6
40 / 1016	19.5 / 8.9
54 / 1372	25 / 11.4

### 2.1.4 Backwashing Cartridges

The filter device shall have a weir extending above the cartridge deck that encloses the high flow rate filter cartridges when placed in their respective cartridge receptacles within the cartridge deck. The weir shall collect a pool of water during inflow events that subsequently automatically backwashes the hi flo rate cartridges when the inflow event subsides. All filter cartridges shall allow for use of a manual backwashing or filtration membrane rinsing procedure to restore flow capacity and sediment capacity and extend cartridge service life.

### 2.1.5 Maintenance Access to Captured Pollutants

A Maintenance Access Wall shall enclose an opening in the cartridge deck that has minimum diameter of 18 inches (450 mm) and thereby provide suitable access for removal of accumulated floatable pollutants and sediment.

### 2.1.6 Bend Structure

The device shall be able to be used as a bend structure with minimum angles between inlet and outlet pipes of 66-degrees or less in the stormwater conveyance system.

### 2.1.7 Double-Wall Containment of Hydrocarbons

The precast concrete device shall provide double-wall containment for hydrocarbon spill capture by a combined means of an inner wall of fiberglass, to a minimum depth of 12 inches (305 mm) below the cartridge deck and the precast vessel wall. Alternatively, a device constructed of fiberglass (FRP) does not require double-wall containment as fiberglass is resistant to hydrocarbon penetration.



### 2.1.8 Separator Skirt

The device shall provide a flexible separator skirt that extends from the underside of the cartridge deck to a minimum length equal to the length of the membrane filter elements. The separator skirt shall serve as a baffle to protect the membrane filter elements from contamination by floatables and coarse sediment.

### 2.1.9 Sump

The device must include a minimum 24 inches (610 mm) of sump below the bottom of the cartridges for sediment accumulation, unless otherwise specified by the design engineer.

## **2.2 Precast Concrete Sections**

All precast concrete components shall be manufactured to a minimum live load of HS-20 truck loading or greater based on local regulatory specifications, unless otherwise modified or specified by the design engineer.

## **2.3 Gaskets**

All gaskets used for the concrete joints shall be manufactured using neoprene or nitrile rubber gaskets to prevent deterioration from presence of captured petroleum hydrocarbons. Mastic sealants or butyl tape are not an acceptable alternative as they are prone to leakage of petroleum hydrocarbons.

## **2.4 Frame and Cover**

Frame and covers must be manufactured from cast-iron and embossed with the name of the device manufacturer or the device brand name.

## **2.5 Doors and Hatches**

If provided shall meet designated loading requirements at a minimum for incidental traffic.

## **2.5 Concrete**

All concrete components shall be manufactured according to local specifications and shall meet the requirements of ASTM C 478.

## **2.6 Fiberglass**

The fiberglass portion of the water treatment device shall be constructed in accordance with the following standard: ASTM D-4097: Contact Molded Glass Fiber Reinforced Chemical Resistant Tanks.

## **2.7 Steps**

Steps shall be constructed according to ASTM D4101 of copolymer polypropylene and be driven into preformed or pre-drilled holes after the concrete has cured, installed to conform to applicable sections of state, provincial and municipal building codes, highway, municipal or local specifications for the construction of such devices.

## **2.8 Inspections**

All precast concrete sections shall be inspected to ensure that dimensions, appearance and quality of the product meet local municipal specifications and ASTM C 478.



## Part 3 – Performance

### 3.1 General

#### 3.1.1 Function

The stormwater quality filter treatment device functions to remove pollutants by the following unit treatment processes; sedimentation, floatation and membrane filtration.

#### 3.1.2 Pollutants

The stormwater quality filter treatment device removes oil, debris, trash, sediment, sediment-bound pollutants, metals and nutrients from stormwater during frequent wet weather events.

#### 3.1.3 Bypass

The stormwater quality filter treatment device typically operates off-line.

#### 3.1.4 Treatment Flux Rate

The stormwater quality filter treatment device shall treat 100% of the required water quality treatment flow based on a maximum treatment flux rate across the membrane filter cartridges of 0.21 gpm/ft<sup>2</sup> (0.142 lps/m<sup>2</sup>).

### 3.2 Field Test Performance

At a minimum, the stormwater quality filter device shall have been field tested with a minimum 25 TARP qualifying storm events and field monitoring conducted according to the TARP or TAPE field test protocol, and have received NJCAT verification.

#### 3.2.1 Suspended Solids Removal

The stormwater quality filter treatment device shall have demonstrated a minimum median TSS removal efficiency of greater than 85%, and a minimum median SSC removal of 95%.

#### 3.2.2 Fine Particle Removal

The stormwater quality filter treatment device shall demonstrate the ability to capture fine particles as indicated by a minimum median removal efficiency of all particles less than 25 microns greater than 75%, an effluent d<sub>50</sub> of 15 microns or lower for all monitored storm events, and an effluent turbidity of 15 NTUs or lower.

#### 3.2.3 Nutrient (Total Phosphorus & Total Nitrogen) Removal

The stormwater quality filter treatment device shall have demonstrated a minimum median Total Phosphorus removal of 55%, and a minimum median Total Nitrogen removal of 50%.

#### 3.2.4 Metals (Total Zinc & Total Copper) Removal

The stormwater quality filter treatment device shall have demonstrated a minimum median Total Zinc removal of 55%, and a minimum median Total Copper removal of 85%.



### 3.3 Lab Test Performance

#### 3.3.1 Suspended Solids Removal

The stormwater quality treatment device shall demonstrate the ability to remove a minimum of 85% of Sil-Co-Sil 106 ( $d_{50} = 22$  microns), measured as SSC, with a 95% confidence interval at the system's 100% operating rate with influent sediment concentrations ranging from 100 to 300 mg/L.

### 3.4 Inspection and Maintenance

The stormwater quality filter device shall have the following features:

3.4.1 The membrane filter elements shall be designed to last three years prior to requiring replacement.

3.4.2 Inspection which includes trash and floatables collection, sediment depth determination, and visible determination of backwash pool depth shall be easily conducted from grade.

3.4.3 Manual backflushing of the filter cartridges shall be possible to restore the flow capacity and sediment capacity of the filter cartridges and therefore extend cartridge service life.

3.4.4 Filter treatment shall have a minimum 12 inches (610 mm) of sediment storage depth.

3.4.5 Sediment removal from the filter treatment device shall be conducted using a standard maintenance truck and vacuum apparatus, and a single point of entry through the cartridge deck that is unobstructed by filter cartridges.

3.4.6 Filter cartridges be easily maintained without the use of additional lifting equipment.

## Part 4 – Execution

### 4.1 Precast & Installation

#### 4.1.1 Precast Device Construction Sequence

The installation of a precast concrete device should conform to ASTM C 891 and to any state highway, municipal or local specifications for the construction of manholes. Selected sections of a general specification that are applicable are summarized below.

4.1.1.1 The precast concrete device is installed in sections in the following sequence:

- aggregate base
- base slab
- treatment chamber and cartridge deck riser section(s)
- bypass section
- connect inlet and outlet pipes
- riser section and/or transition slab (if required)
- maintenance riser section(s) (if required)
- frame and access cover



4.1.1.2 The precast base should be placed level at the specified grade. The entire base should be in contact with the underlying compacted granular material. Subsequent sections, complete with joint seals, should be installed in accordance with the precast concrete manufacturer's recommendations.

4.1.1.3 Adjustment of the stormwater quality treatment device can be performed by lifting the upper sections free of the excavated area, re-leveling the base, and re-installing the sections. Damaged sections and gaskets should be repaired or replaced as necessary. Once the stormwater quality treatment device has been constructed, any lift holes must be plugged watertight with mortar or non-shrink grout.

#### 4.1.4 Inlet and Outlet Pipes

Inlet and outlet pipes should be securely set into the device using approved pipe seals (flexible boot connections, where applicable) so that the structure is watertight.

#### 4.1.5 Frame and Cover Installation

Adjustment units (e.g. grade rings) should be installed to set the frame and cover at the required elevation. The adjustment units should be laid in a full bed of mortar with successive units being joined using sealant recommended by the manufacturer. Frames for the cover should be set in a full bed of mortar at the elevation specified.

#### 4.2.1 Fiberglass (FRP) Installation

The installation of the FRP device should conform to applicable sections of state, provincial and municipal building codes, highway, municipal or local specifications for the construction of such devices. Selected sections of a general specification that are applicable are summarized below. For detailed installation instructions refer to the submitted drawing and installation details.

##### 4.2.1.1 Structural

Proposed installation details shall conform with all federal, provincial, state, municipal or other local specifications as may be applicable, including all building code requirements. Structural - Proposed installation details shall conform with all federal, provincial, state, municipal or other local specifications as may be applicable, including all building code requirements.

##### 4.2.1.2 Water Quality Device Construction Sequence

The water quality FRP device is installed in the following sequence:

- Water quality device as delivered to site placed on prepared bedding or slab using spreader bars and the lifting lugs provided on the structure. Avoid lifting chains or cables from contacting sides of tank. Do not drop, roll or slide vessel.
- Backfill using approved back fill material
- Pour anti-buoyancy slab as required per the drawing
- Connect inlet and outlet pipes
- Riser sections and/or transitions (if required and if shipped separately)
- Frame and access cover

##### 4.2.1.3 Frame and Cover Installation

No direct structural connection shall be permitted to any FRP maintenance access surface riser pipe. No vertical structural connection shall be permitted to any FRP component under any circumstances unless approved by the manufacturer.



A minimum 1-inch (25 mm) gap shall be left around and above any required FRP maintenance access surface risers (i.e. not a buried installation), with this gap filled with pea gravel or approved fill material against the surrounding structure that must support the frame and cover in its entirety.

#### **4.3 Maintenance Access Wall**

In some instances the Maintenance Access Wall will require an extension attachment and sealing to the precast wall and cartridge deck at the job site, rather than at the precast facility. In this instance, installation of these components shall be performed according to instructions provided by the manufacturer.

#### **4.4 Filter Cartridge Installation**

Filter cartridges shall be installed in the cartridge deck after the construction site is fully stabilized, unless otherwise specified by the design engineer.

## **Part 5 – Quality Assurance**

### **5.1 Filter Cartridge Installation**

Manufacturer shall coordinate delivery of filter cartridges and other internal components with contractor. Filter cartridges shall be delivered and installed after site is stabilized and unit is ready to accept cartridges. Contractor shall take appropriate action to protect the filter cartridge receptacles and filter cartridges from damage during construction. For systems with cartridges installed prior to full site stabilization and prior to system commissioning, the contractor can plug inlet and outlet pipes to prevent stormwater from entering the device. Plugs must be removed after the device has been commissioned.

### **5.2 Inspection and Maintenance**

#### 5.2.1

The manufacturer shall provide an Owner's Manual upon request.

#### 5.2.2

After construction and installation, and during operation, the device shall be inspected and cleaned as necessary based on the manufacturer's recommended inspection and maintenance guidelines.

### **5.3 Replacement Filter Cartridges**

When replacement membrane filter elements and/or other parts are required, only membrane filter elements and parts approved by the manufacturer for use with the stormwater quality filter device shall be installed.



# Appendix C

---

## Jellyfish® Filter Design Form





# Jellyfish Filter Design Form



## Project Information

Project Name: \_\_\_\_\_  
 Jobsite Address: \_\_\_\_\_  
 \_\_\_\_\_  
 City/Town: \_\_\_\_\_  
 State/Province: \_\_\_\_\_

## Contractor Information

Contact Name: \_\_\_\_\_  
 Company: \_\_\_\_\_  
 Phone Number: \_\_\_\_\_  
 Fax Number: \_\_\_\_\_  
 E-Mail: \_\_\_\_\_

## Consultant Information

Contact Name: \_\_\_\_\_  
 Company: \_\_\_\_\_  
 Phone Number: \_\_\_\_\_  
 Fax Number: \_\_\_\_\_  
 E-Mail: \_\_\_\_\_

## Owner Information

Contact Name: \_\_\_\_\_  
 Company: \_\_\_\_\_  
 Phone Number: \_\_\_\_\_  
 Fax Number: \_\_\_\_\_  
 E-Mail: \_\_\_\_\_

## Design Information

Outlet Pipe Size: \_\_\_\_\_  
 Outlet Pipe Material: \_\_\_\_\_  
 Upstream Weir Elev: \_\_\_\_\_  
 Drainage Area: \_\_\_\_\_  
 % Impervious: \_\_\_\_\_

Inlet Pipe Size: \_\_\_\_\_  
 Inlet Pipe Material: \_\_\_\_\_  
 Internal Bypass Required (Y/N): \_\_\_\_\_  
 Treatment Flow Rate: \_\_\_\_\_  
 Peak Bypass Flow Rate: \_\_\_\_\_  
 Detention on site (Y/N): \_\_\_\_\_  
 Filter Installed Downstream of Detention (Y/N): \_\_\_\_\_

Online\* or Offline: \_\_\_\_\_  
 If Online:  
 5 year flow rate: \_\_\_\_\_  
 Max Inlet pipe flow rate: \_\_\_\_\_

\*Online available in select markets

Please sketch inlet pipe location below and mark angle

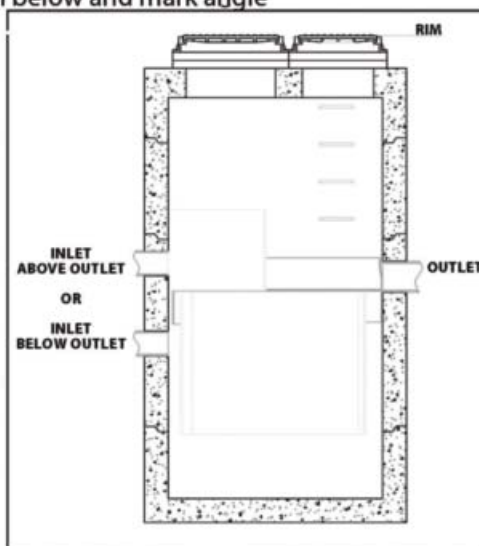
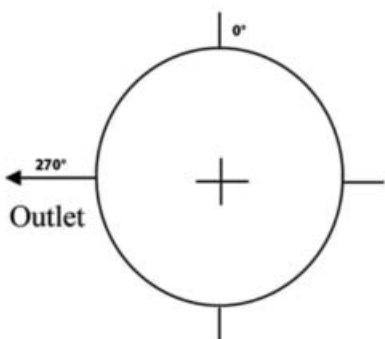

Notes: \_\_\_\_\_  
 \_\_\_\_\_  
 \_\_\_\_\_  
 \_\_\_\_\_  
 \_\_\_\_\_  
 \_\_\_\_\_  
 \_\_\_\_\_  
 \_\_\_\_\_  
 \_\_\_\_\_



### For Office Use Only

Jellyfish Filter Model: \_\_\_\_\_  
 Imbrium Project Number: \_\_\_\_\_  
 Quote Number: \_\_\_\_\_  
 Submit Form to: Imbrium Systems  
 USA: 888.279.8826 CAD: 800.565.4801 INT'L: +1.416.960.9900

Notes



# Jellyfish<sup>®</sup> Filter

## General Design Notes

### Driving Head

- ✓ Typical driving head designed into the system is 18 inches (457 mm)
- ✓ Off-line configuration has an external bypass that uses an upstream diversion structure to provide the 18 inches (457 mm) of driving head

### Inlet & Outlet Pipes

- ✓ A wide range of angles can be accommodated
  - The inlet pipe can be located anywhere about the structure circumference
  - The separation angle relationship between the inlet pipe and outlet pipe can vary from 0 to 360 degrees providing maximum design flexibility.
- ✓ Multiple inlet pipes can be accommodated
- ✓ For the standard above-deck configuration, the inlet pipe's invert elevation is typically set 6 inches (150 mm) higher than the invert elevation of the outlet pipe.
  - Alternative invert elevations between the inlet and outlet pipe can easily be accommodated with most all configurations

### Minimum Cover

- ✓ Low cover installations generally need a minimum depth of cover of 36 inches (915 mm) from the outlet pipe invert to the underside of the top slab.

### Cartridge Details:

- Design flow rates for the 54-inch (1372 mm) length:
  - hi-flo cartridge: 80 gpm (5.0 L/s)
  - draindown cartridge: 40 gpm (2.5 L/s)
- Design membrane filtration flux rate (flow rate per unit surface area) for the 54-inch (1372 mm) length:
  - hi-flo cartridge: 0.21 gpm/ft<sup>2</sup> (0.14 Lps/m<sup>2</sup>)
  - draindown cartridge: 0.11 gpm/ft<sup>2</sup> (0.07 Lps/m<sup>2</sup>)
- Weight for the 54-inch (1372 mm) length:
  - Dry weight < 20 pounds (9 kg)
  - Wet weight < 50 pounds (23 kg)



**imbrium**<sup>®</sup>  
Engineered Stormwater Treatment  
[www.imbriumsystems.com](http://www.imbriumsystems.com)

**USA**

**Phone:** 301.279.8827  
**Toll Free:** 888.279.8826

**Canada / International**

**Phone:** 416.960.9900  
**Toll Free:** 800.565.4801

**Int'l:** +1.416.960.9900