

# *Stormceptor*<sup>®</sup> **EF**

## Owner's Manual

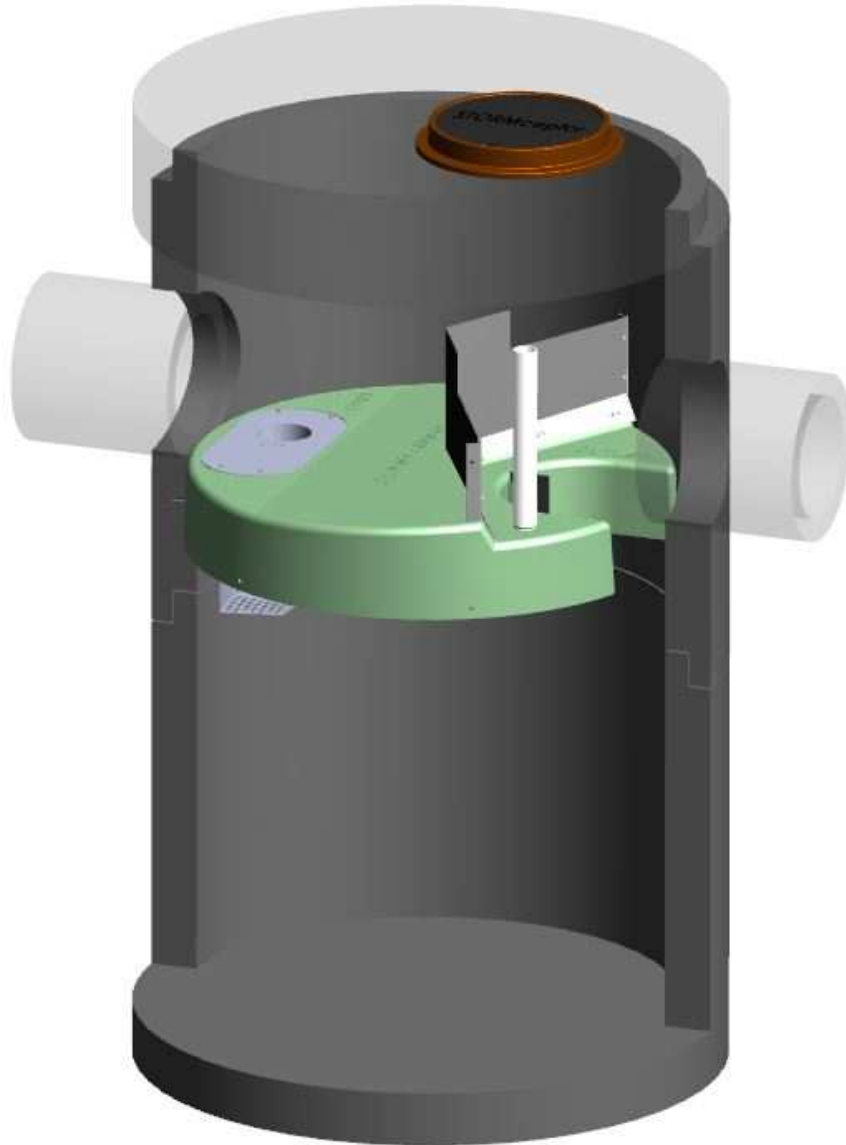

*Stormceptor is protected by one or more of the following patents:*

Canadian Patent No. 2,137,942  
Canadian Patent No. 2,180,305  
Canadian Patent No. 2,327,768  
Canadian Patent No. 2,694,159  
Canadian Patent No. 2,697,287  
U.S. Patent No. 6,068,765  
U.S. Patent No. 6,371,690  
U.S. Patent No. 7,582,216  
U.S. Patent No. 7,666,303  
Australia Patent No. 693.164  
Australia Patent No. 729,096  
Australia Patent No. 2008,279,378  
Australia Patent No. 2008,288,900  
Japanese Patent No. 5,997,750  
Japanese Patent No. 5,555,160  
Korean Patent No. 0519212  
Korean Patent No. 1451593  
New Zealand Patent No. 583,008  
New Zealand Patent No. 583,583  
South African Patent No. 2010/00682  
South African Patent No. 2010/01796  
Patent pending

## **Table of Contents:**

**1 - Stormceptor EF Overview**

**2 - Stormceptor EF Operation, Components**

**3 - Stormceptor EF Model Details**

**4 - Stormceptor EF Identification**

**5 - Stormceptor EF Inspection & Maintenance**

**6 – Stormceptor Contacts**

## OVERVIEW

**Stormceptor® EF** is a continuation and evolution of the most globally recognized oil grit separator (OGS) stormwater treatment technology - **Stormceptor®**. Also known as a hydrodynamic separator, the enhanced flow Stormceptor EF is a high performing oil grit separator that effectively removes a wide variety of pollutants from stormwater and snowmelt runoff at flow rates higher than the original Stormceptor. Stormceptor EF captures and retains sediment (TSS), free oils, gross pollutants and other pollutants that attach to particles, such as nutrients and metals. Stormceptor EF's patent-pending treatment and scour prevention platform ensures sediment is retained during all rainfall events.

Stormceptor EF offers design flexibility in one simplified platform, accepting stormwater flow from a single inlet pipe, multiple inlet pipes, and/or from the surface through an inlet grate. Stormceptor EF can also serve as a junction structure, accommodate a 90-degree inlet to outlet bend angle, and be modified to ensure performance in submerged conditions. With its scour prevention and internal bypass, Stormceptor EF can be installed online, eliminating the need for costly additional bypass structures.

## OPERATION

- Stormwater enters the Stormceptor upper chamber through the inlet pipe(s) or a surface inlet grate. A specially designed insert reduces the influent velocity by creating a pond upstream of the insert's weir. Sediment particles immediately begin to settle. Swirling flow sweeps water, sediment, and floatables across the sloped surface of the insert to the inlet opening of the drop pipe, where a strong vortex draws water, sediment, oil, and debris down the drop pipe cone.
- Influent exits the cone into the drop pipe duct. The duct has two large rectangular outlet openings as well as perforations in the backside and floor of the duct. Influent is diffused through these various opening in multiple directions and at low velocity into the lower chamber.
- Free oils and other floatables rise up within the channel surrounding the central riser pipe and are trapped beneath the insert, while sediment settles to the sump. Pollutants are retained for later removal during maintenance cleaning.
- Treated effluent enters the outlet riser, moves upward, and discharges to the top side of the insert downstream of the weir, where it flows out the outlet pipe.
- During intense storm events with very high influent flow rates, the pond height on the upstream side of the weir may exceed the height of the weir, and the excess flow passes over the top of the weir to the downstream side of the insert, and exits through the outlet pipe. This internal bypass feature allows for in-line installation, avoiding the cost of additional bypass structures. During bypass, the pond separates sediment from all incoming flows, while full treatment in the lower chamber continues at the maximum flow rate.
- Stormceptor EF's patent-pending enhanced flow and scour prevention technology ensures pollutants are captured and retained, allowing excess flows to bypass during infrequent, high intensity storms.

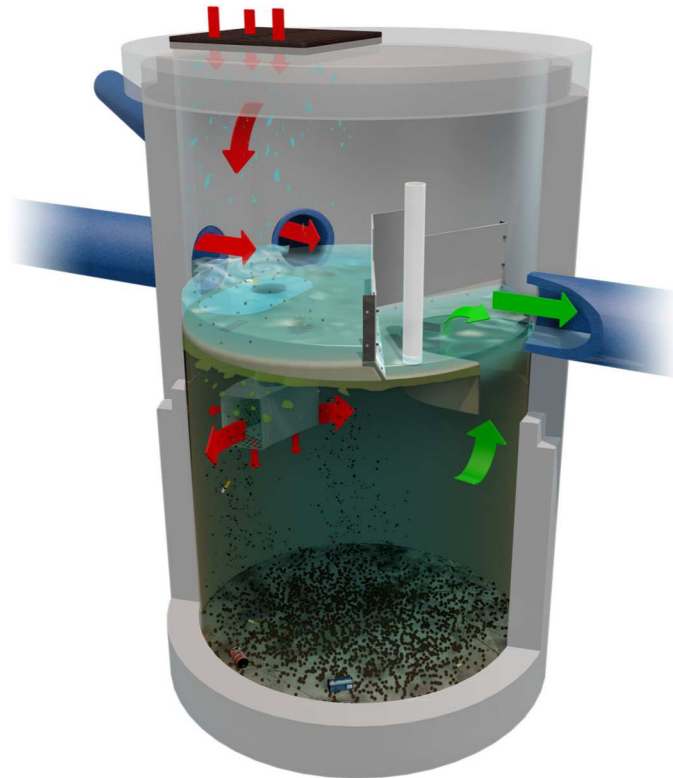

## COMPONENTS

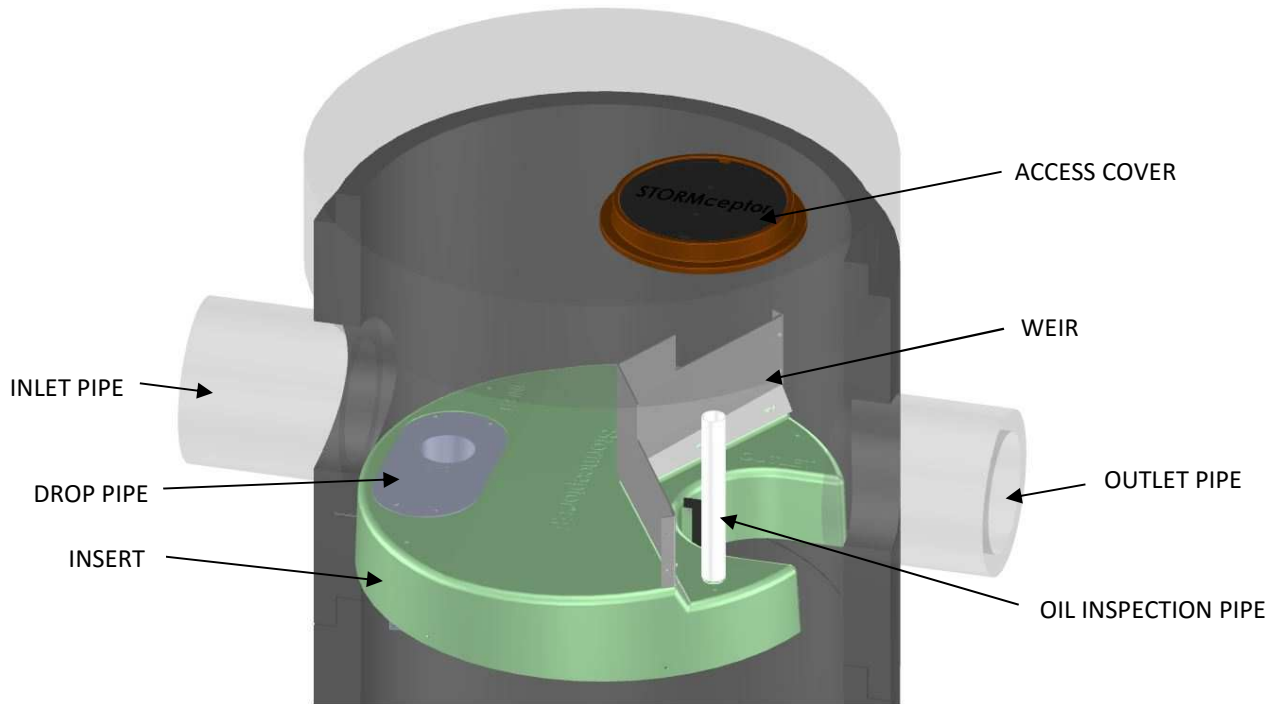

Figure 1

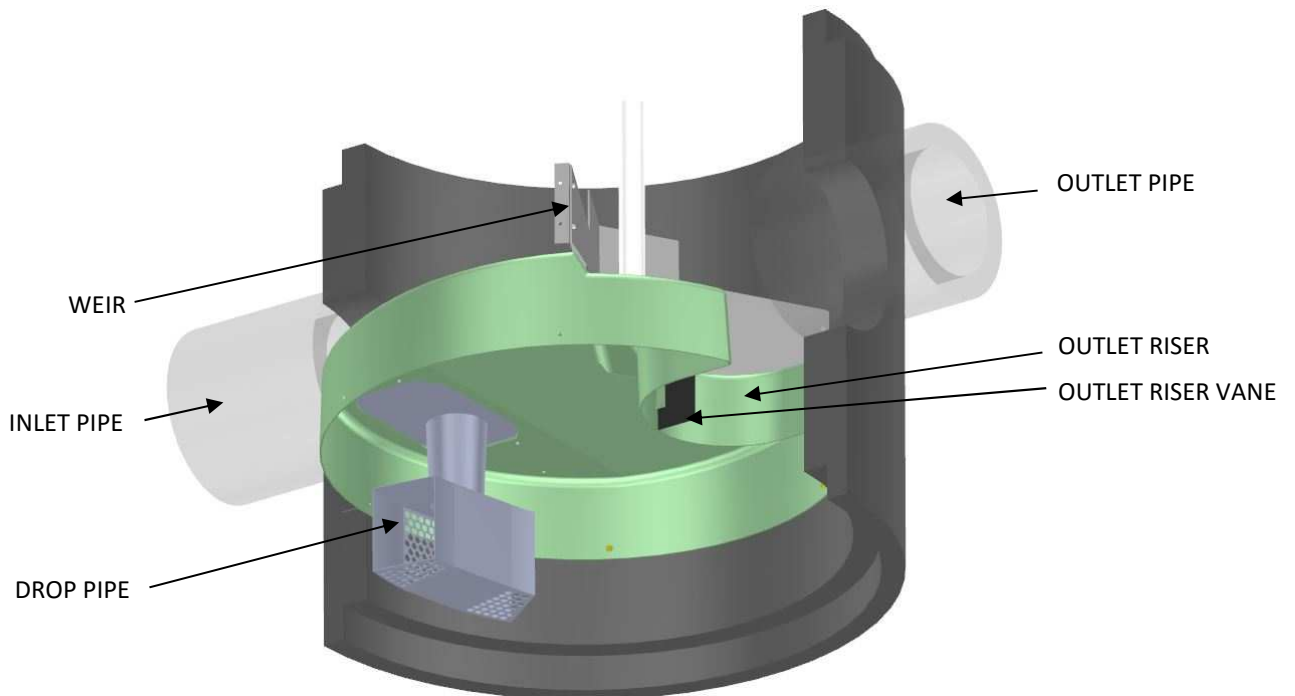

Figure 2

OUTLET PLATFORM (UP position)

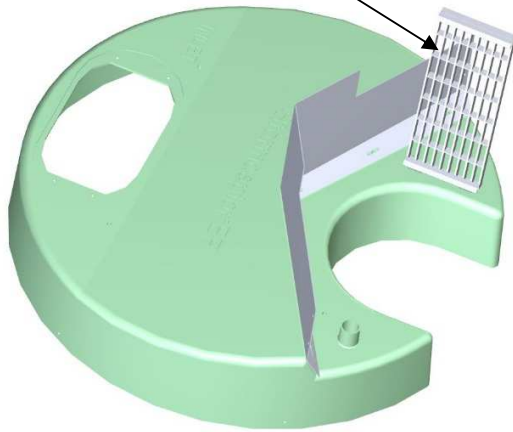

Figure 3A

OUTLET PLATFORM (DOWN position)

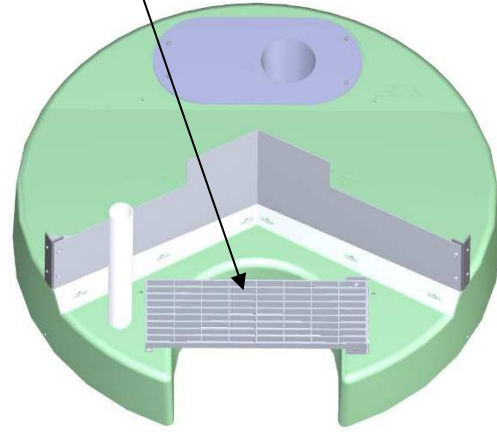

Figure 3B

- **Insert** – separates vessel into upper and lower chambers, and provides double-wall containment of hydrocarbons
- **Weir** – creates stormwater ponding and driving head on top side of insert
- **Drop pipe** – conveys stormwater and pollutants into the lower chamber
- **Outlet riser** – conveys treated stormwater from the lower chamber to the outlet pipe, and provides primary inspection and maintenance access into the lower chamber
- **Outlet riser vane** – prevents formation of a vortex in the outlet riser during high flow rate conditions
- **Outlet platform (optional)** – safety platform in the event of manned entry into the unit
- **Oil inspection pipe** – primary access for measuring oil depth

## PRODUCT DETAILS

### METRIC DIMENSIONS AND CAPACITIES

Table 1

Stormceptor Model	Inside Diameter (m)	Minimum Surface to Outlet Invert Depth (mm)	Depth Below Outlet Pipe Invert (mm)	Wet Volume (L)	Sediment Capacity <sup>1</sup> (m <sup>3</sup> )	Hydrocarbon Storage Capacity <sup>2</sup> (L)	Maximum Flow Rate into Lower Chamber <sup>3</sup> (L/s)	Peak Conveyance Flow Rate <sup>4</sup> (L/s)
EF4 / EFO4	1.22	915	1524	1780	1.19	265	22.1 / 10.4	425
EF6 / EFO6	1.83	915	1930	5070	3.47	610	49.6 / 23.4	990
EF8 / EFO8	2.44	1219	2591	12090	8.78	1070	88.3 / 41.6	1700
EF10 / EFO10	3.05	1219	3251	23700	17.79	1670	138 / 65	2830
EF12 / EFO12	3.66	1524	3886	40800	31.22	2475	198.7 / 93.7	2830

<sup>1</sup> Sediment Capacity is measured from the floor to the bottom of the drop pipe cone. Sediment Capacity can be increased to accommodate specific site designs and pollutant loads. Contact your local representative for assistance.

<sup>2</sup> Hydrocarbon Storage Capacity is measured from the bottom of the outlet riser to the underside of the insert. Hydrocarbon Storage Capacity can be increased to accommodate specific site designs and pollutant loads. Contact your local representative for assistance.

<sup>3</sup> EF Maximum Flow Rate into Lower Chamber is based on a maximum surface loading rate (SLR) into the lower chamber of 1135 L/min/m<sup>2</sup>. EFO Maximum Flow Rate into Lower Chamber is based on a maximum surface loading rate (SLR) into the lower chamber of 535 L/min/m<sup>2</sup>.

<sup>4</sup> Peak Conveyance Flow Rate is limited by a maximum velocity of 1.5 m/s.

### U.S. DIMENSIONS AND CAPACITIES

Table 2

Stormceptor Model	Inside Diameter (ft)	Minimum Surface to Outlet Invert Depth (in)	Depth Below Outlet Pipe Invert (in)	Wet Volume (gal)	Sediment Capacity <sup>1</sup> (ft <sup>3</sup> )	Hydrocarbon Storage Capacity <sup>2</sup> (gal)	Maximum Flow Rate into Lower Chamber <sup>3</sup> (cfs)	Peak Conveyance Flow Rate <sup>4</sup> (cfs)
EF4 / EFO4	4	36	60	471	42	70	0.78 / 0.37	15
EF6 / EFO6	6	36	76	1339	123	160	1.75 / 0.83	35
EF8 / EFO8	8	48	102	3194	310	280	3.12 / 1.47	60
EF10 / EFO10	10	48	128	6261	628	440	4.87 / 2.30	100
EF12 / EFO12	12	60	153	10779	1103	655	7.02 / 3.31	100

<sup>1</sup> Sediment Capacity is measured from the floor to the bottom of the drop pipe cone. Sediment Capacity can be increased to accommodate specific site designs and pollutant loads. Contact your local representative for assistance.

<sup>2</sup> Hydrocarbon Storage Capacity is measured from the bottom of the outlet riser to the underside of the insert. Hydrocarbon Storage Capacity can be increased to accommodate specific site designs and pollutant loads. Contact your local representative for assistance.

<sup>3</sup> EF Maximum Flow Rate into Lower Chamber is based on a maximum surface loading rate (SLR) into the lower chamber of 27.9 gpm/ft<sup>2</sup>. EFO Maximum Flow Rate into Lower Chamber is based on a maximum surface loading rate (SLR) into the lower chamber of 13.1 gpm/ft<sup>2</sup>.

<sup>4</sup> Peak Conveyance Flow Rate is limited by a maximum velocity of 5 fps.



## IDENTIFICATION

Each Stormceptor EF/EFO unit is easily identifiable by the trade name **Stormceptor®** embossed on the access cover at grade as shown in **Figure 3**. The tradename **Stormceptor®** is also embossed on the top of the insert upstream of the weir as shown in **Figure 3**.

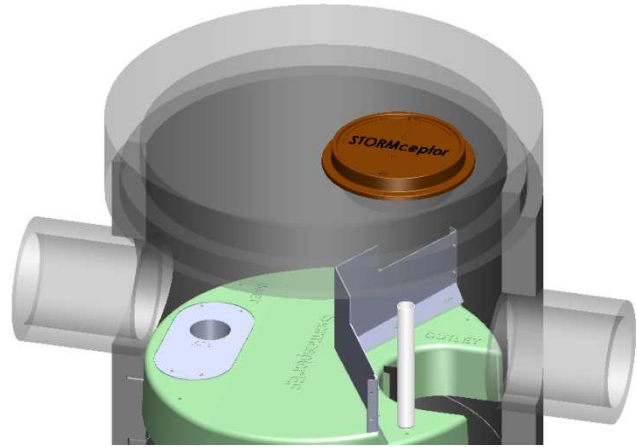

**Figure 4**

The specific Stormceptor EF/EFO model number is identified on the top of the aluminum Drop Pipe as shown in **Figure 4**. The unit serial number is identified on the top of the insert upstream of the weir as shown in **Figure 4**.

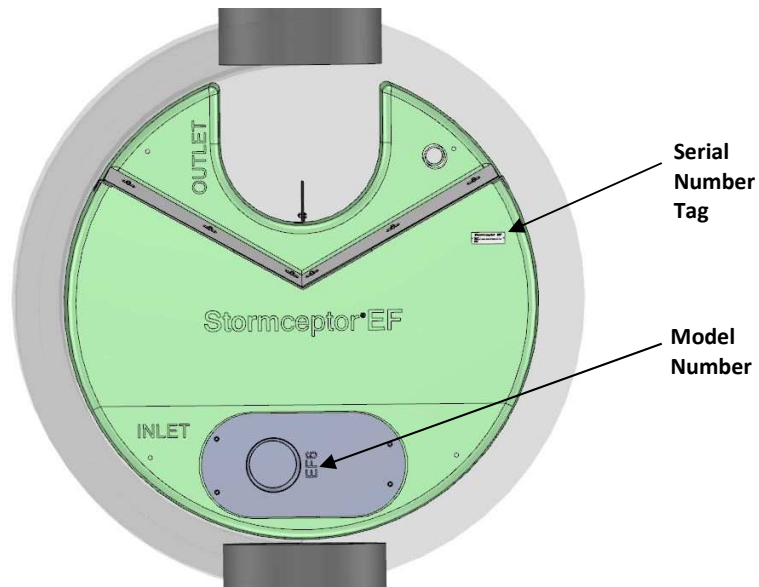

**Figure 5**

## INSPECTION AND MAINTENANCE

It is very important to perform regular inspection and maintenance. Regular inspection and maintenance ensures maximum operation efficiency, keeps maintenance costs low, and provides continued of natural waterways.

### Quick Reference

- Typical inspection and maintenance is performed from grade
- Remove manhole **cover(s)** or **inlet grate** to access insert and lower chamber  
NOTE: EF4/EFO4 requires the removal of a **flow deflector** beneath inlet grate
- Use Sludge Judge® or similar sediment probe to check sediment depth through the **outlet riser**
- Oil dipstick can be inserted through the **oil inspection pipe**
- Visually inspect the **insert** for debris, remove debris if present
- Visually inspect the **drop pipe** opening for blockage, remove blockage if present
- Visually inspect **insert** and **weir** for damage, schedule repair if needed
- Insert vacuum hose and jetting wand through the outlet riser and extract sediment and floatables
- Replace flow deflector (EF4/EFO4), inlet grate, and cover(s)
- **NOTE:** If the unit has an **outlet platform**, the outlet platform is typically in the UP position (see Figure 3A) for normal treatment conditions, and for inspection and maintenance. If manned entry into the unit is required, the outlet platform must first be placed in the DOWN position (see Figure 3B). After manned entry is completed, return the outlet platform to the UP position for treatment.

### *When is inspection needed?*

- Post-construction inspection is required prior to putting the Stormceptor into service.
- Routine inspections are recommended during the first year of operation to accurately assess pollutant accumulation.
- Inspection frequency in subsequent years is based on the maintenance plan developed in the first year.
- Inspections should also be performed immediately after oil, fuel, or other chemical spills.

### *What equipment is typically required for inspection?*

- Manhole access cover lifting tool
- Oil dipstick / Sediment probe with ball valve (typically ¾-inch to 1-inch diameter)
- Flashlight
- Camera
- Data log / Inspection Report
- Safety cones and caution tape
- Hard hat, safety shoes, safety glasses, and chemical-resistant gloves

### ***When is maintenance cleaning needed?***

- If the post-construction inspection indicates presence of construction sediment of a depth greater than a few inches, maintenance is recommended at that time.
- For optimum performance and normal operation the unit should be cleaned out once the sediment depth reaches the recommended maintenance sediment depth, see **Table 3**.
- Maintain immediately after an oil, fuel, or other chemical spill.

**Table 3**

<b>Recommended Sediment Depths for Maintenance Service*</b>	
<b>MODEL</b>	<b>Sediment Depth (in/mm)</b>
EF4 / EFO4	8 / 203
EF6 / EFO6	12 / 305
EF8 / EFO8	24 / 610
EF10 / EFO10	24 / 610
EF12 / EFO12	24 / 610

\* Based on a minimum distance of 40 inches (1,016 mm) from bottom of outlet riser to top of sediment bed

The frequency of inspection and maintenance may need to be adjusted based on site conditions to ensure the unit is operating and performing as intended. Maintenance costs will vary based on the size of the unit, site conditions, local requirements, disposal costs, and transportation distance.

### ***What equipment is typically required for maintenance?***

- Vacuum truck equipped with water hose and jet nozzle
- Small pump and tubing for oil removal
- Manhole access cover lifting tool
- Oil dipstick / Sediment probe with ball valve (typically ¾-inch to 1-inch diameter)
- Flashlight
- Camera
- Data log / Inspection Report
- Safety cones
- Hard hats, safety shoes, safety glasses, chemical-resistant gloves, and hearing protection for service providers
- Gas analyzer, respiratory gear, and safety harness for specially trained personnel if confined space entry is required (adhere to all OSHA / CCOSH standards)

### ***What conditions can compromise Stormceptor performance?***

- Presence of construction sediment and debris in the unit prior to activation
- Excessive sediment depth beyond the recommended maintenance depth
- Oil spill in excess of the oil storage capacity
- Clogging or restriction of the drop pipe inlet opening with debris
- Downstream blockage that results in a backwater condition

## Maintenance Procedures

- Maintenance should be conducted during dry weather conditions when no flow is entering the unit.
- Stormceptor is maintained from grade through a standard surface manhole access cover or inlet grate.
- In the case of submerged or tailwater conditions, extra measures are likely required, such as plugging the inlet and outlet pipes prior to conducting maintenance.
- Inspection and maintenance of upstream catch basins and other stormwater conveyance structures is also recommended to extend the time between future maintenance cycles.
- Sediment depth inspections are performed through the **Outlet Riser** and oil presence can be determined through the **Oil Inspection Pipe**.
- Oil presence and sediment depth are determined by inserting a Sludge Judge® or measuring stick to quantify the pollutant depths.

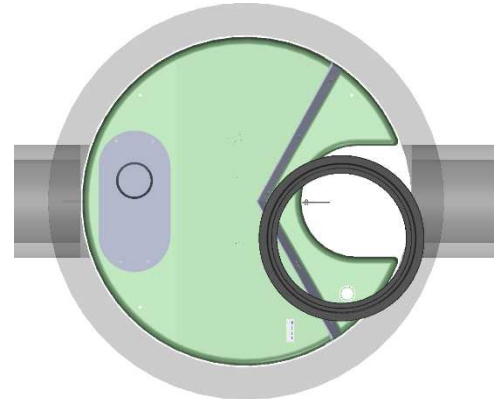

Figure 6

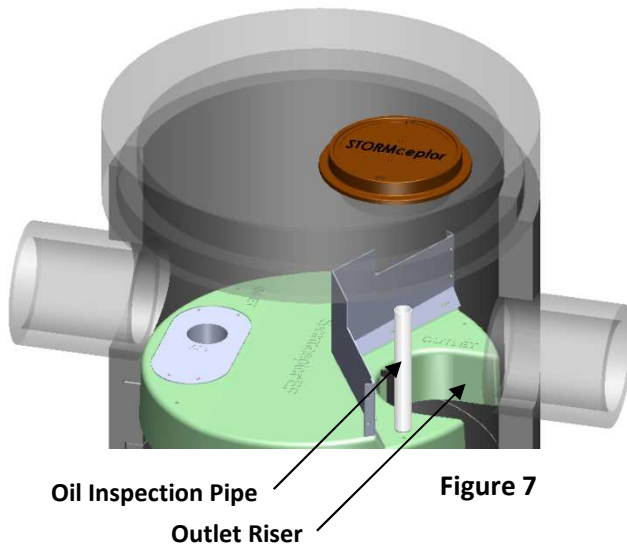

Figure 7



Figure 8

- Visually inspect the insert, weir, and drop pipe inlet opening to ensure there is no damage or blockage.
- **NOTE:** If the unit has an **outlet platform**, the outlet platform is typically in the UP position (see Figure 3A) for normal treatment conditions, and for inspection and maintenance. If manned entry into the unit is required, the outlet platform must first be placed in the DOWN position (see Figure 3B). After manned entry is completed, return the outlet platform to the UP position for treatment.

- When maintenance is required, a standard vacuum truck is used to remove the pollutants from the lower chamber of the unit through the **Outlet Riser**.



**Figure 9**

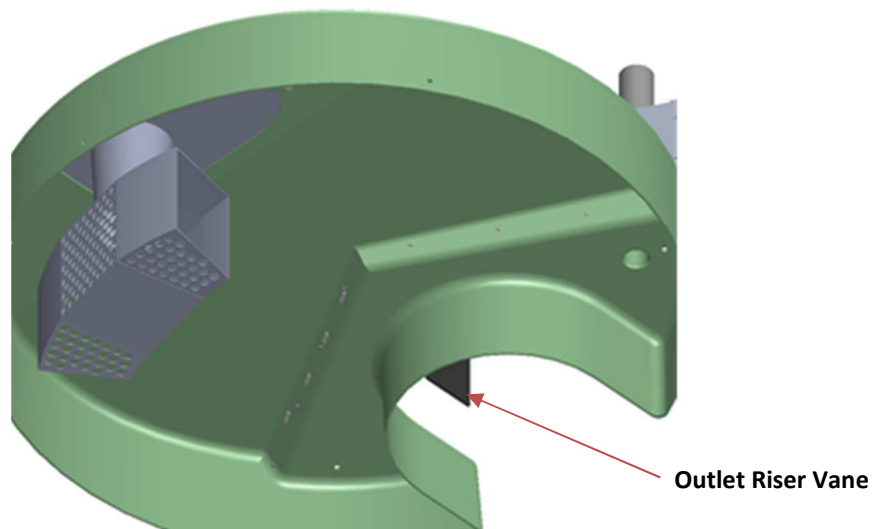

**Figure 10**

NOTE: The Outlet Riser Vane is durable and flexible and designed to allow maintenance activities with minimal, if any, interference.

## Removable Flow Deflector

- Top grated inlets for the Stormceptor EF4/EFO4 model requires a removable flow deflector staged underneath a 24-inch x 24-inch (600 mm x 600 mm) square inlet grate to direct flow towards the inlet side of the insert, and avoid flow and pollutants from entering the outlet side of the insert from grade. The EF6/EFO6 and larger models do not require the flow deflector.

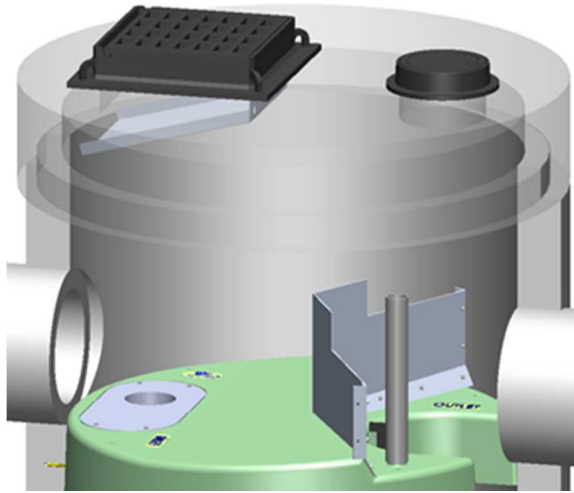
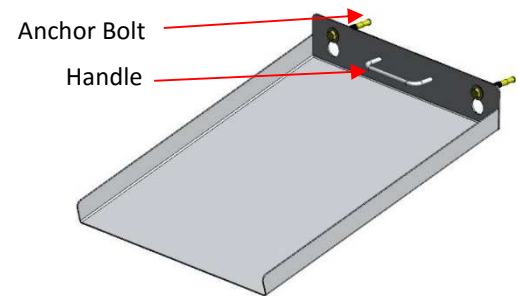

Figure 11

### How to Remove:

1. Loosen anchor bolts
2. Pull up and out using the handle



Removable Flow Deflector

## Hydrocarbon Spills

Stormceptor is often installed on high pollutant load hotspot sites with vehicular traffic where hydrocarbon spill potential exists. Should a spill occur, or presence of oil be identified within a Stormceptor EF/EFO, it should be cleaned immediately by a licensed liquid waste hauler.

## Disposal

Maintenance providers are to follow all federal, state/ provincial, and local requirements for disposal of material.

## Oil Sheens

When oil is present in stormwater runoff, a sheen may be noticeable at the Stormceptor outlet. An oil rainbow or sheen can be noticeable at very low oil concentrations (< 10 mg/L). Despite the appearance of a sheen, Stormceptor EF/EFO may still be functioning as intended.

## Oil Level Alarm

To mitigate spill liability with 24/7 detection, an electronic monitoring system can be employed to trigger a visual and audible alarm when a pre-set level of oil is captured within the lower chamber or when an oil spill occurs. The oil level alarm is available as an optional feature to include with Stormceptor EF/EFO as shown in **Figure 11**. For additional details about the Oil Level Alarm please visit <http://www.imbriumsystems.com/stormwater-treatment-solutions/stormceptor-systems>.

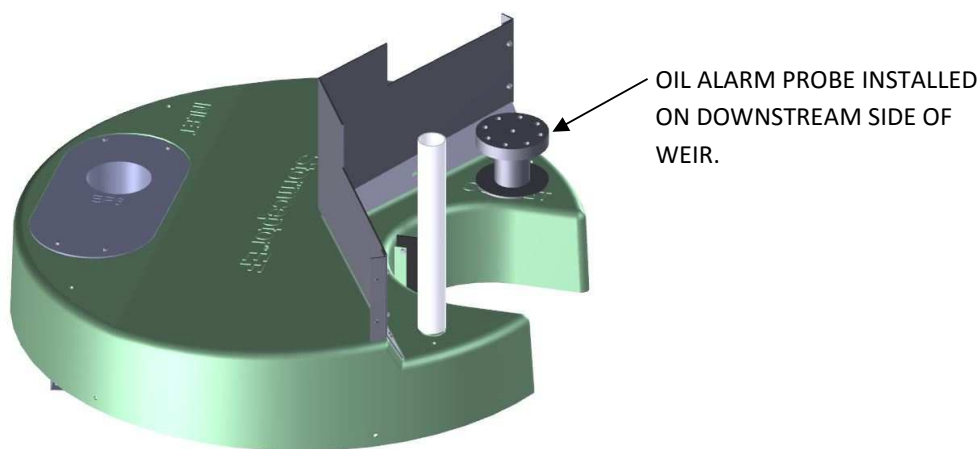

**Figure 12**

## Replacement Parts

Stormceptor has no moving parts to wear out. Therefore inspection and maintenance activities are generally focused on pollutant removal. Since there are no moving parts during operation in a Stormceptor, broken, damaged, or worn parts are not typically encountered. However, if replacement parts are necessary, they may be purchased by contacting your local Stormceptor representative.

## Stormceptor Inspection and Maintenance Log

Stormceptor Model No: \_\_\_\_\_

Serial Number: \_\_\_\_\_

Installation Date: \_\_\_\_\_

Location Description of Unit: \_\_\_\_\_

Recommended Sediment Maintenance Depth: \_\_\_\_\_

<b>DATE</b>	<b>SEDIMENT DEPTH (inch or mm)</b>	<b>OIL DEPTH (inch or mm)</b>	<b>SERVICE REQUIRED (Yes / No)</b>	<b>MAINTENANCE PERFORMED</b>	<b>MAINTENANCE PROVIDER</b>	<b>COMMENTS</b>

Other Comments:



## Contact Information

Questions regarding Stormceptor EF/EFO can be addressed by contacting your local Stormceptor representative or by visiting our website at [www.stormceptor.com](http://www.stormceptor.com).

### Imbrium Systems Inc. & Imbrium Systems LLC

Canada            1-416-960-9900 / 1-800-565-4801  
United States    1-301-279-8827 / 1-888-279-8826  
International    +1-416-960-9900 / +1-301-279-8827

[www.imbriumsystems.com](http://www.imbriumsystems.com)

[www.stormceptor.com](http://www.stormceptor.com)

[info@imbriumsystems.com](mailto:info@imbriumsystems.com)